

ISC-PDL1-WAC30G



Professional Series
TriTech+ Curtain Detectors
with Anti-mask
Installation manual

Optional mounting brackets:
B328, B335, B338
Optional mounting brackets not tested by UL.

Bosch Security Systems B.V.
Torenallee 49
5617 BA Eindhoven
Netherlands
www.boschsecurity.com



ISC-PDL1-WAC30G:

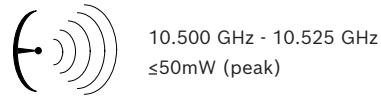

Use only a Listed Class 2 Power Limited Source.
For UL Listed product installations, the Listed control unit
or a Listed burglary power supply must provide four hours of
standby power.

2.1 m - 3 m
(7 ft - 10 ft)

58 mm
(2.25 in.)

136 mm
(5.25 in.)

69 mm
(2.75 in.)

≤4.5 kg (10 lb)

< 93%

-30°C - +55°C (-22°F - +131°F)

For UL Listed Installations, the temperature range is 0°C - +49°C
(+32°F - +120°F), humidity 93%

1

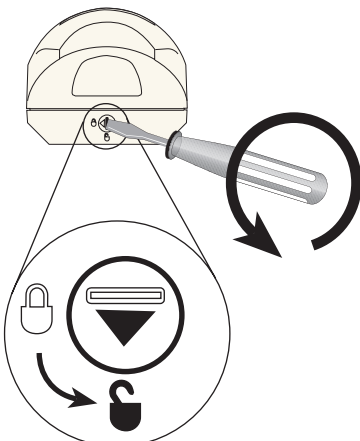

2

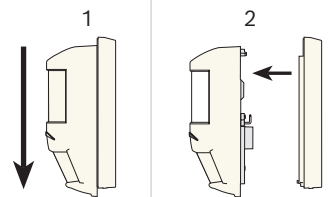

www.boschsecurity.com

© Bosch Security Systems B.V.
F01U287084-06
2023.01

3

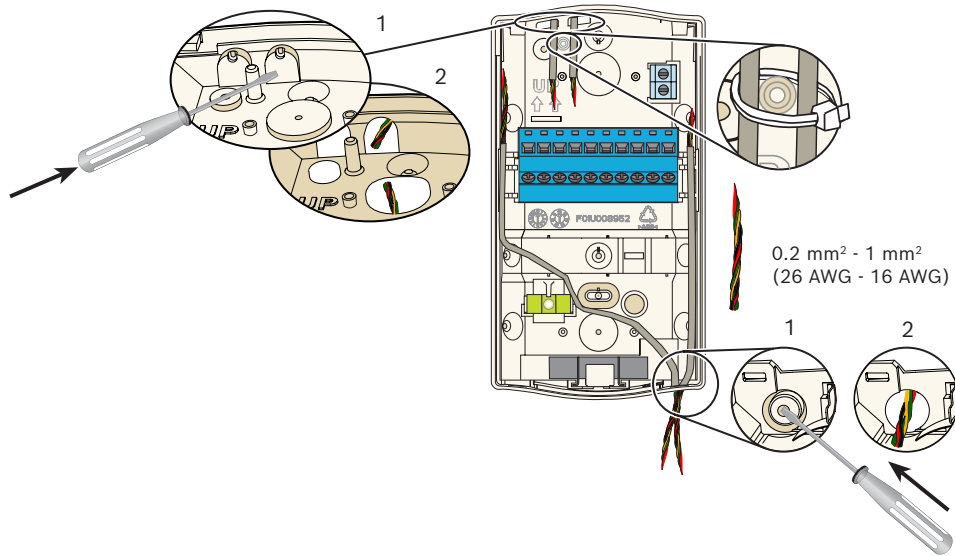

4

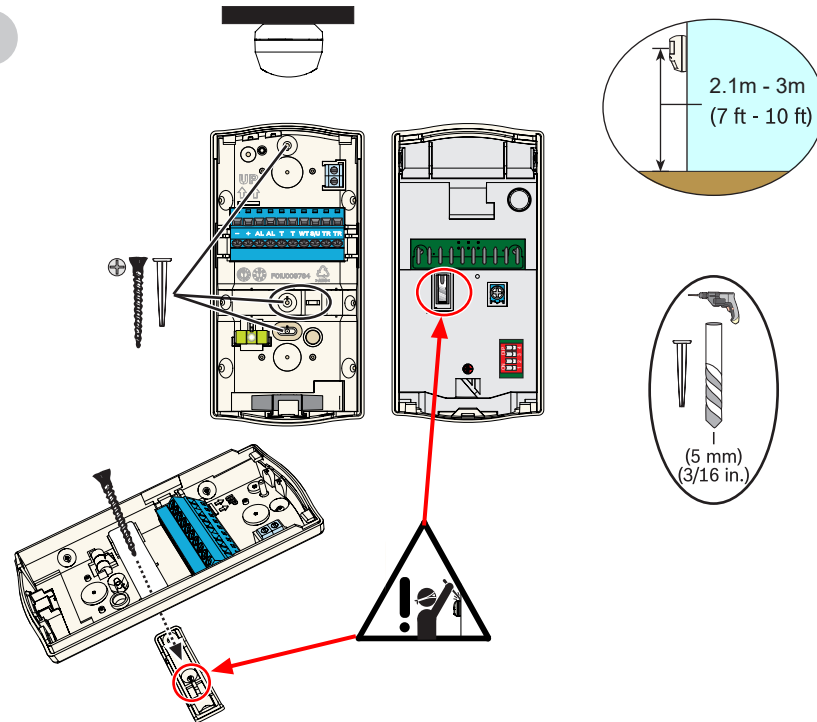

4

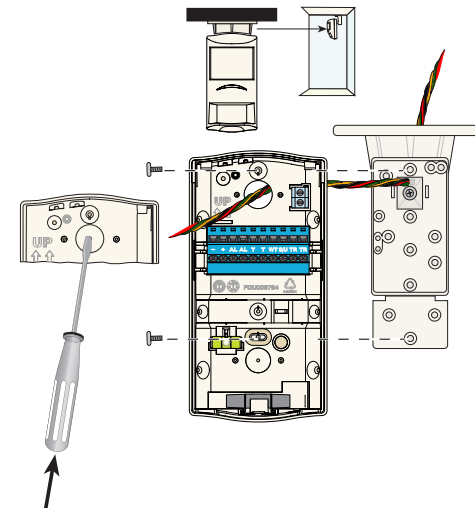
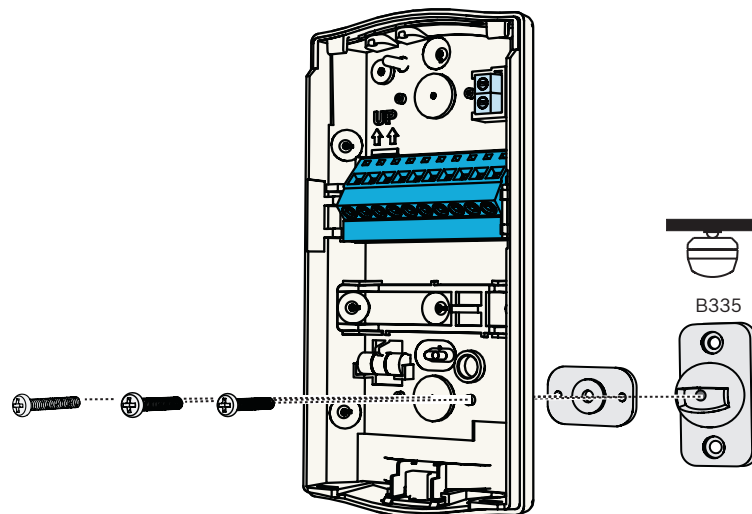
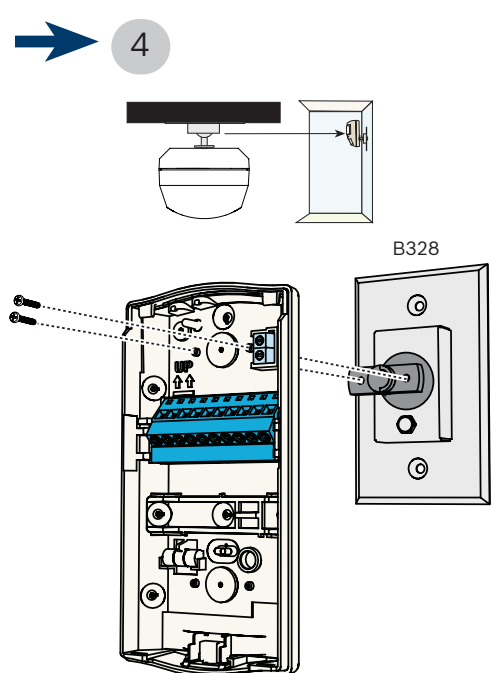

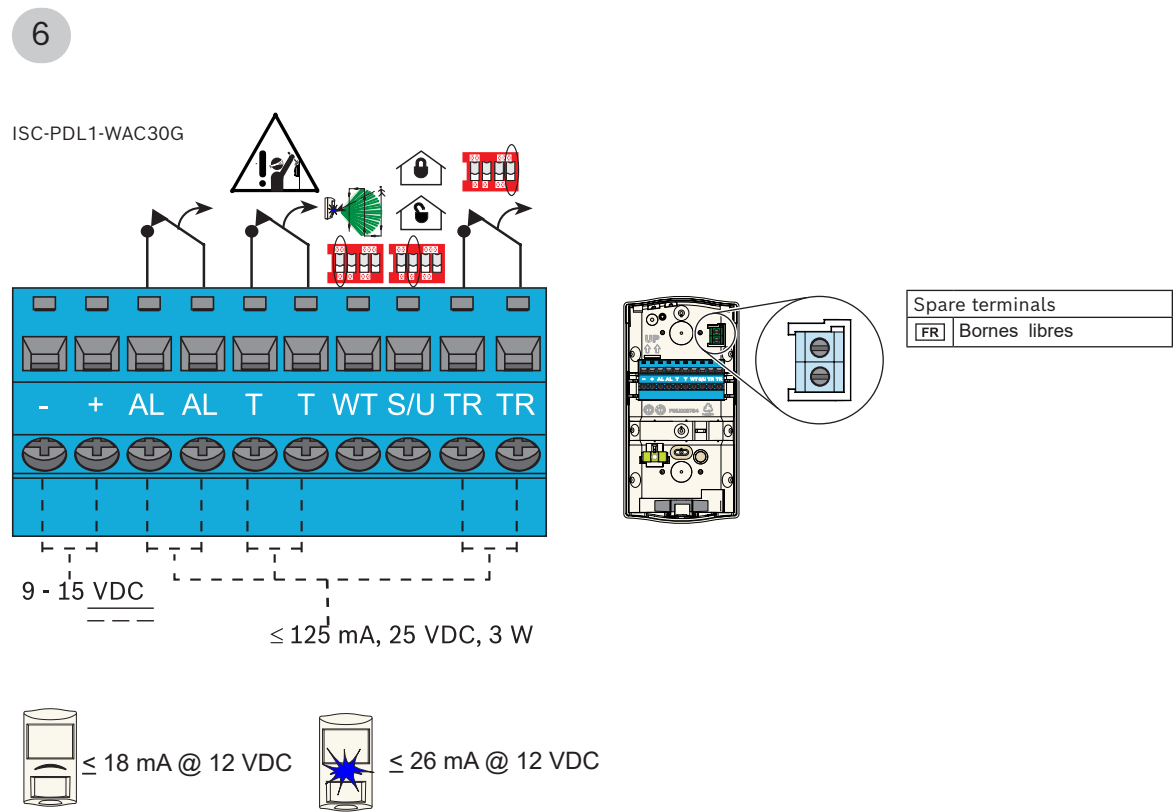
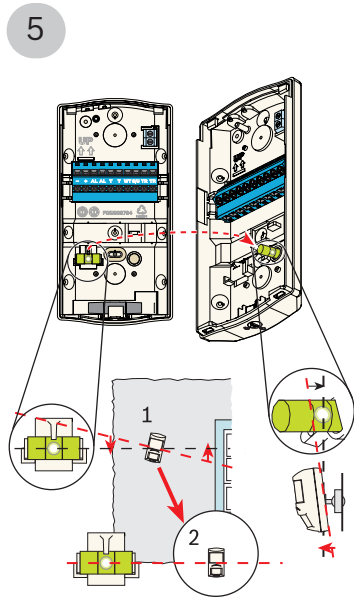
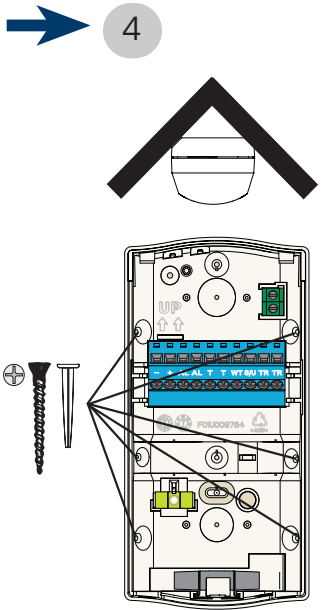

7

DIP switch settings and voltage from the control panel to the terminal determines the state of the feature (Remote Walk Test and Alarm Memory) associated with that terminal.

[FR] La configuration du commutateur DIP et la tension appliquée depuis la centrale à la borne déterminent l'état de la fonction (Test de la détection à distance et Mémoire d'alarme) associée à cette borne.

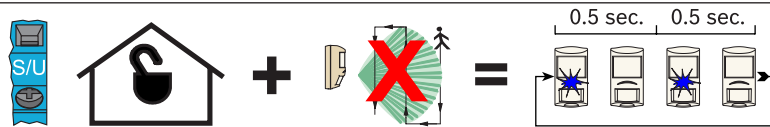

The Alarm Memory function is used when more than one detector is connected to an alarm loop. The Alarm Memory identifies the units experiencing an alarm in the last armed period. The detector stores the alarm event in memory during the armed period. It shows the stored alarm when the system is disarmed. The LED flashes to indicate the stored alarm. Alarm Memory clears when the system is re-armed.

FR La fonction Mémoire d'alarme est utilisée lorsque plusieurs détecteurs sont connectés à un circuit d'alarme. La mémoire d'alarme identifie les appareils dont l'alarme s'est déclenchée lors de la dernière période où le système était armé. Le détecteur stocke chaque événement d'alarme en mémoire durant la période où le système est armé. Il affiche l'alarme mémorisée une fois le système désarmé. Le voyant LED clignote pour indiquer qu'une alarme est mémorisée. La mémoire d'alarme se vide lorsque le système est ré-armé.

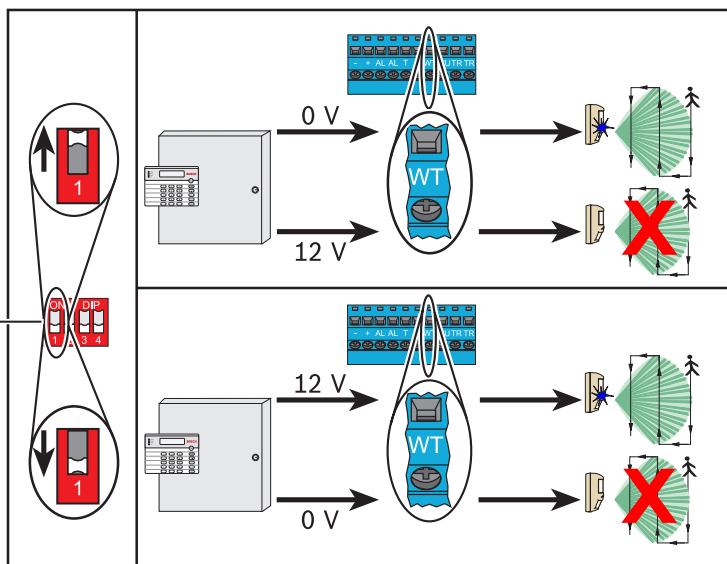
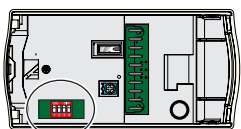

Remote Walk Test (WT)
FR Test de marche à distance (TM)

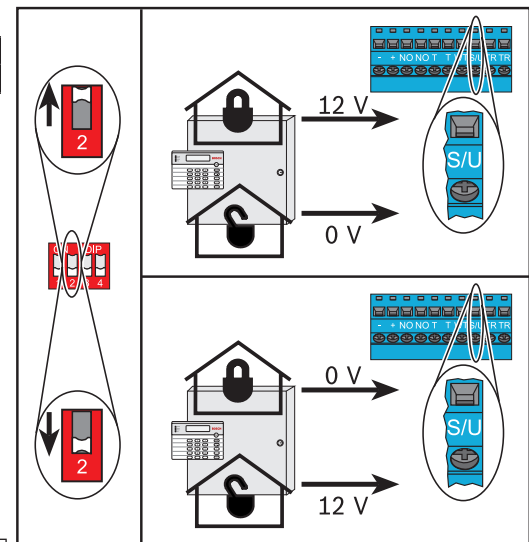

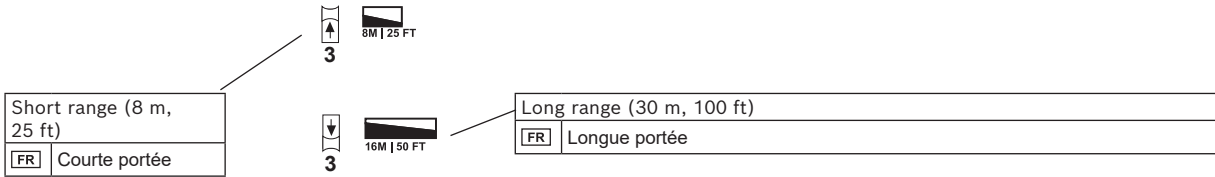

Alarm Memory polarity (S/U)
FR Mémoire d'alarme (S/U)

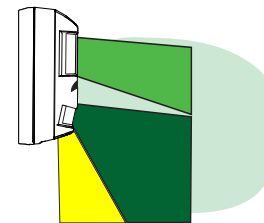
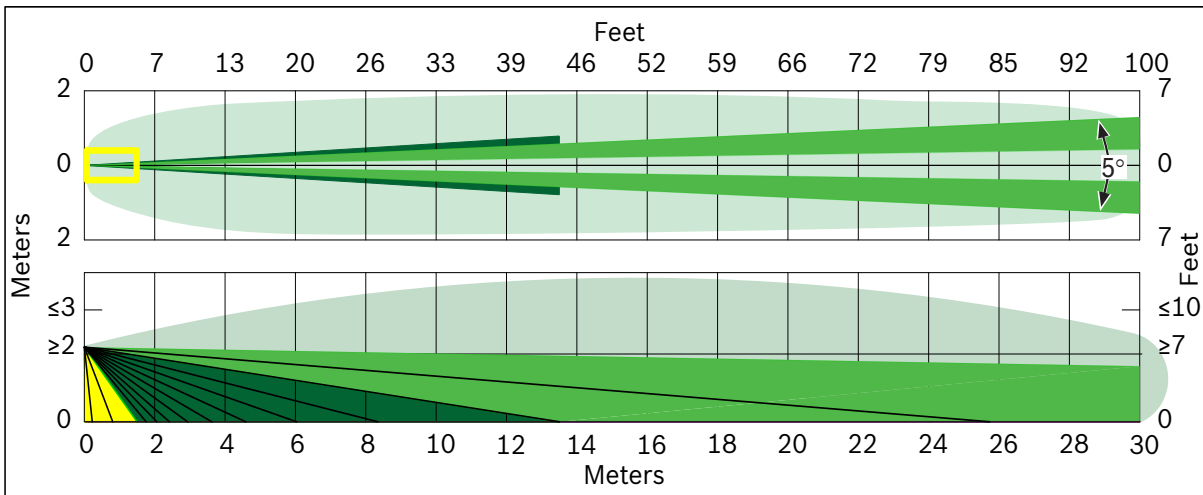
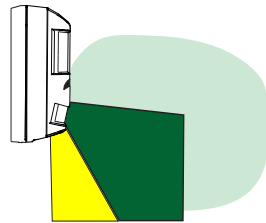
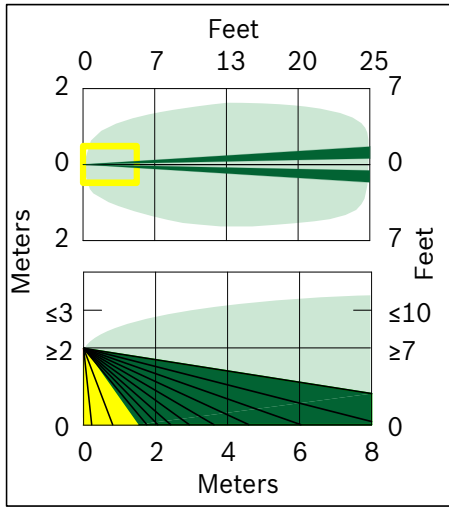

Microwave	Passive infrared (PIR)
[FR] Hyperfréquence	Infrarouge passif (IRP)



	
Antimask off	Antimask on
 Anti-masque inactif	Anti-masque actif

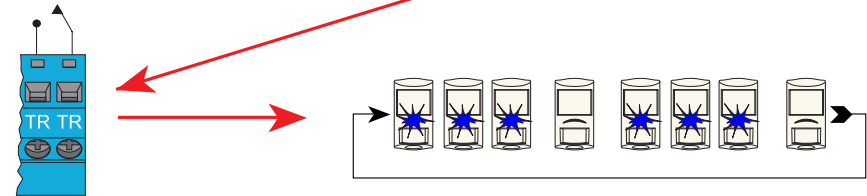
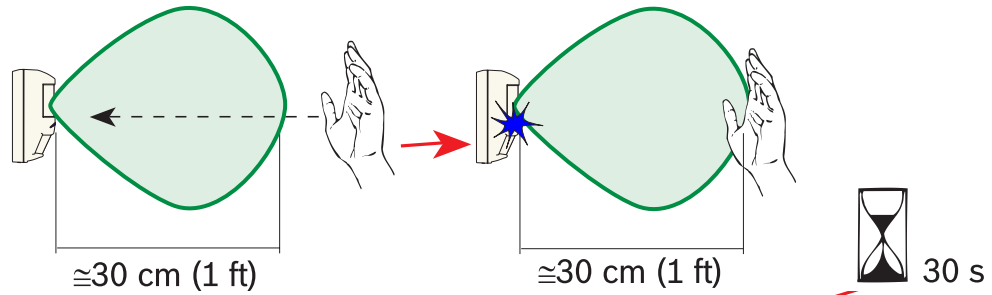

Placement if Antimask feature is enabled
 Emplacement si la fonction anti-masque est activée

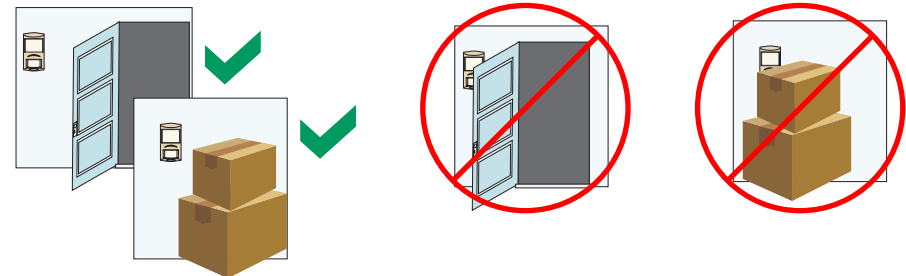

To clear an Antimask condition:

- 1) From the control panel, put the detector into Walk Test Mode. 2)
- 3) Perform a Walk Test. The Antimask condition clears.

Remove the object that is masking the detector.

 Pour effacer une condition d'anti-masque :

- 1) A partir de la centrale, placez le détecteur en mode Test de la détection. 2) Retirez l'objet qui masque le détecteur. 3) Lancez un test de la détection. La condition d'anti-masque est alors effacée.

10

Optional look-down zone
FR Zone optionnelle de détection vers le bas.

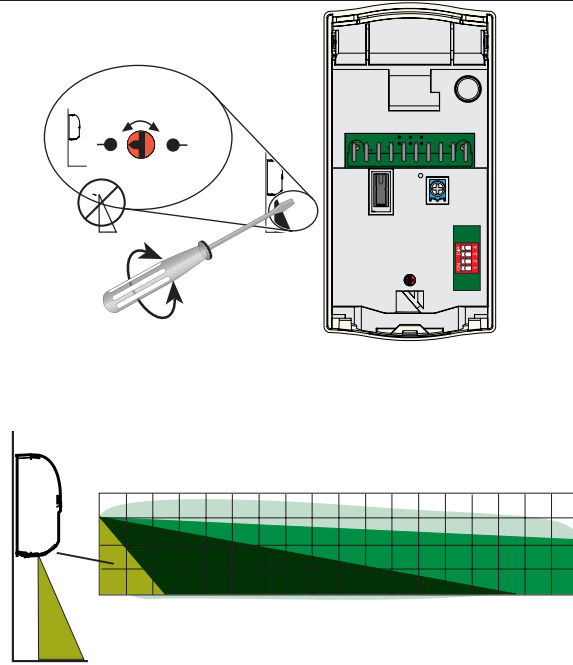

11

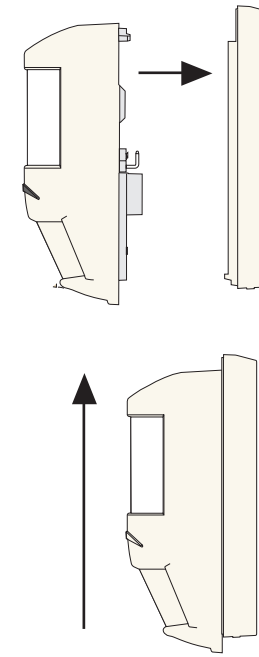

12

If necessary, adjust microwave range slightly until required coverage is met.
FR Au besoin, ajuster légèrement la portée hyperfréquence jusqu'à atteindre le champ de détection souhaité.

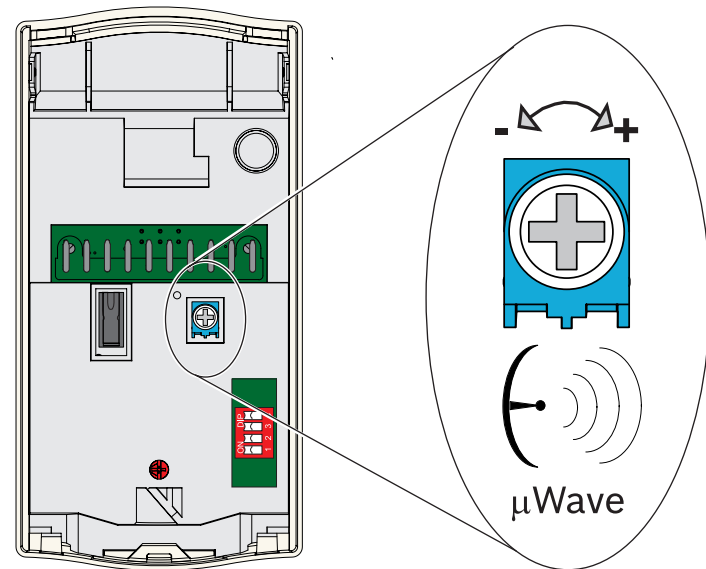



12

No activity	Blue flash: Warming up	Blue: Dual alarm	Yellow: Microwave alarm	Red: PIR alarm
[FR] Aucune activité	Voyant bleu clignotant : Stabilisation	Bleu : Double alarme	Jaune : Alarme hyperfréquence	Rouge : Alarme IRP

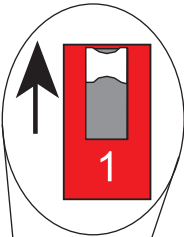

Local Walk Test LED enable	Walk Test LED on	Walk Test LED off
[FR] Activation du voyant LED du test de la détection local	Voyant LED du test de la détection actif	Voyant LED du test de la détection inactif

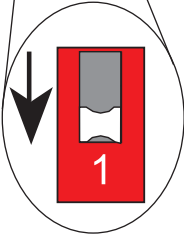
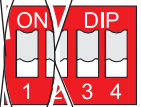

Walk test
[FR] Test de la détection

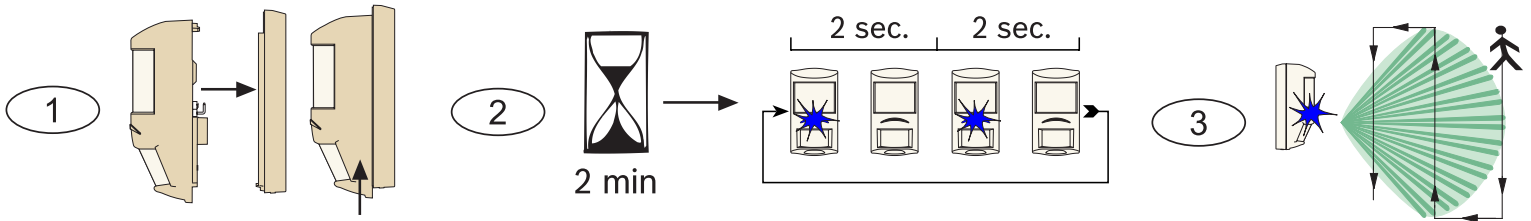

[US] Perform walk test yearly.

Remote Self-Test: Remote Self-test automatically occurs when walk test changes from disabled to enabled (change in terminal voltage).

Important! A passing Remote Self-test responds with an alarm signal.

FR Test automatique à distance : le test automatique à distance est automatiquement activé lorsque le test de la détection passe de inactif à actif (variation de tension sur la borne).
Important ! Lorsque le test automatique à distance réussit, un signal d'alarme continu est généré.

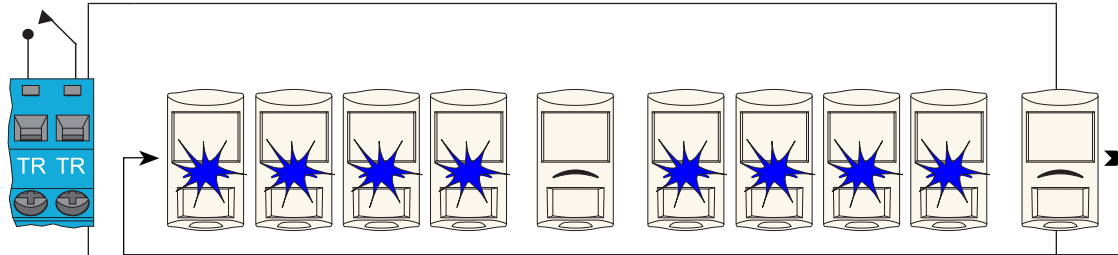
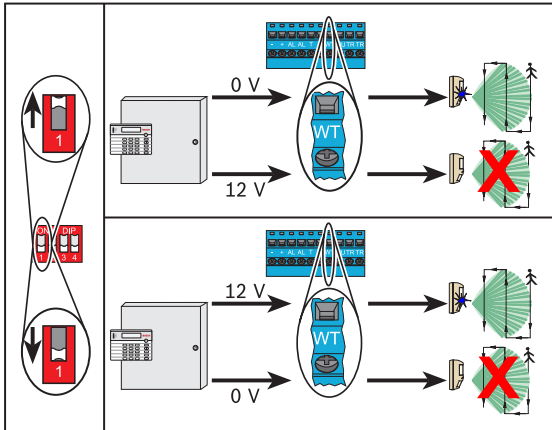
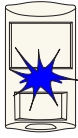
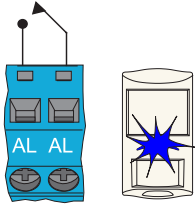

Self-tests every 8 h. Self-test and remote self-test failure: 4 blue flashes

FR Test automatique toutes les 8 heures. Echec du test automatique et du test automatique à distance : 4 clignotements bleus

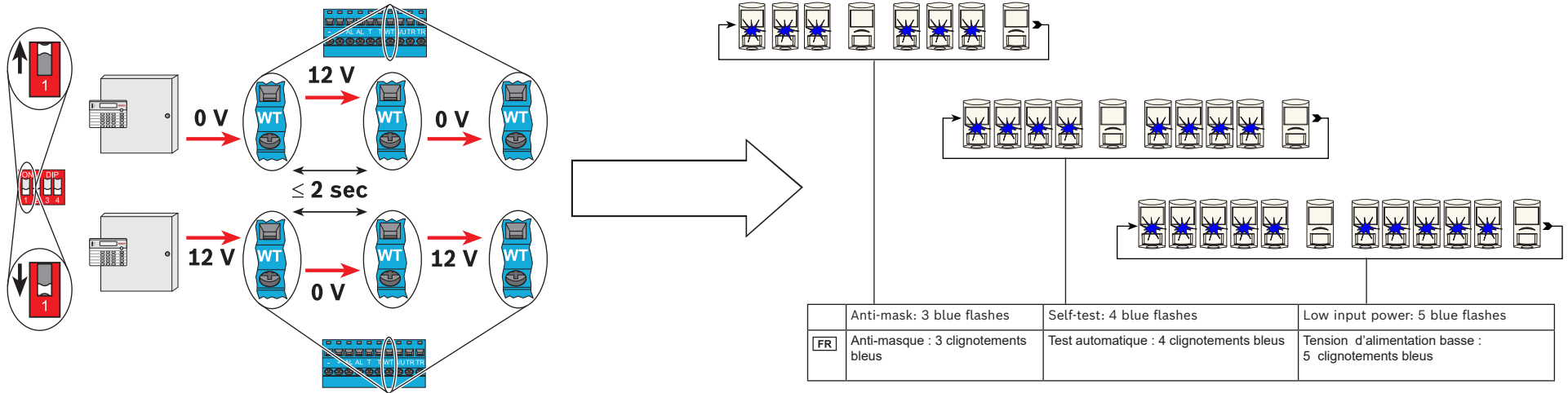

Trouble Memory: Pulse WT input to recall last trouble condition from memory. Pulse WT input again to clear memory. When memory is recalled, it automatically clears after 12 h.

[FR] Mémoire de défaut : Envoyer une impulsion de tension sur WT pour rappeler le dernier défaut mémorisé. Envoyer une impulsion de tension, à nouveau, pour effacer la mémoire. Lorsque la mémoire est rappelée, elle s'efface automatiquement au bout de 12 h.

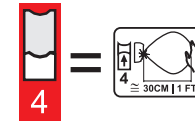
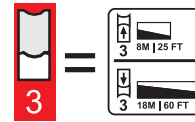
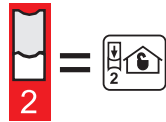





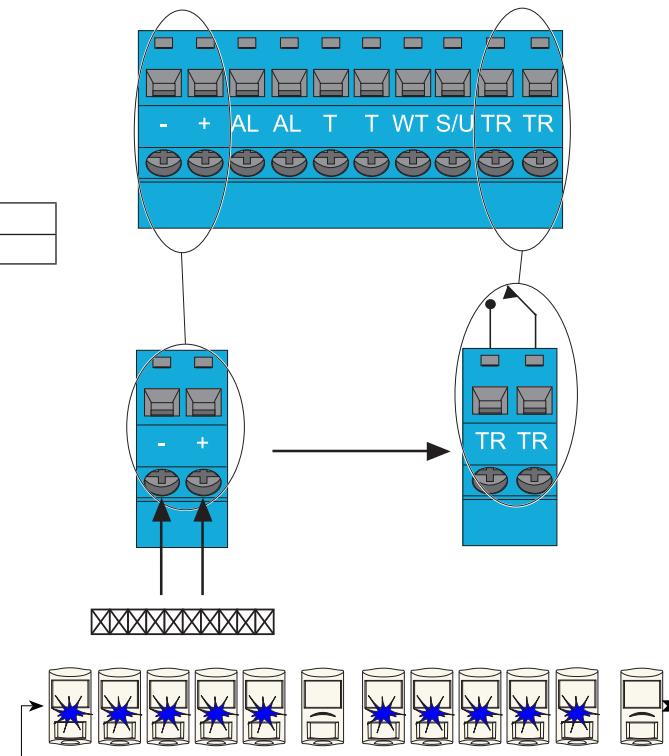

	Local/remote Walk Test LED	Alarm Memory polarity (S/U)	Long range, short range selection	Anti-mask on, off (AM)
[FR]	Voyant LED du test de la détection local/à distance	Polarité définie/non définie (D/ND)	Sélection longue portée, courte portée	Anti-masque actif, inactif (AM)

Low power supervision activates when voltage falls in the range of 6.5 V to 8 V.

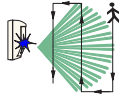
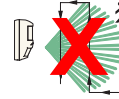
[FR] La surveillance de la tension d'alimentation basse est activée lorsque la tension est comprise entre 6,5 V et 8V.



								
	Wall tamper	System set	System unset	Walk Test LED enabled	Walk Test LED disabled	Short Range Coverage Pattern	Long Range Coverage Pattern	Anti-mask
FR	Autosurveillance à l'ouverture, à l'arrachement, à la réorientation et au champ magnétique	Système activé	Système désactivé	Voyant LED du test de la détection activé	Voyant LED du test de la détection désactivé	Champ de détection courte portée	Champ de détection longue portée	Anti-masque

FCC Compliance Statement

This equipment has been tested and found to comply with the limits for a Class B digital device, pursuant to part 15 of the FCC Rules. These limits are designed to provide reasonable protection against harmful interference in a residential installation. This equipment generates, uses and can radiate radio frequency energy and, if not installed and used in accordance with the instructions, may cause harmful interference to radio communications. However, there is no guarantee that interference will not occur in a particular installation. If this equipment does cause harmful interference to radio or television reception, which can be determined by turning the equipment off and on, the user is encouraged to try to correct the interference by one or more of the following measures:

- Reorient or relocate the receiving antenna.
- Increase the separation between the equipment and receiver.
- Connect the equipment into an outlet on a circuit different from that to which the receiver is connected.
- Consult the dealer or an experienced radio/TV technician for help.

This device complies with Part 15 of the FCC Rules. Operation is subject to the following two conditions:

- (1) this device may not cause harmful interference, and
- (2) this device must accept any interference received, including interference that may cause undesired operation. Please note that changes or modifications not expressly approved by the party responsible for compliance could void the user's authority to operate the equipment.

Changes or modifications not expressly approved by the party responsible for compliance could void the user's authority to operate the equipment.

FCC RF Exposure Statement

This equipment complies with FCC radiation exposure limits set forth for an uncontrolled environment. This transmitter must not be co-located or operating in conjunction with any other antenna or transmitter. In order to avoid the possibility of exceeding the FCC radio frequency exposure limits, this equipment should be installed and operated with minimum distance 20 cm (7.9 inches) between the antenna and your body during normal operation. Users must follow the specific operating instructions for satisfying RF exposure compliance.