

AVENAR detector 4000

FAP-/FAH-425 series

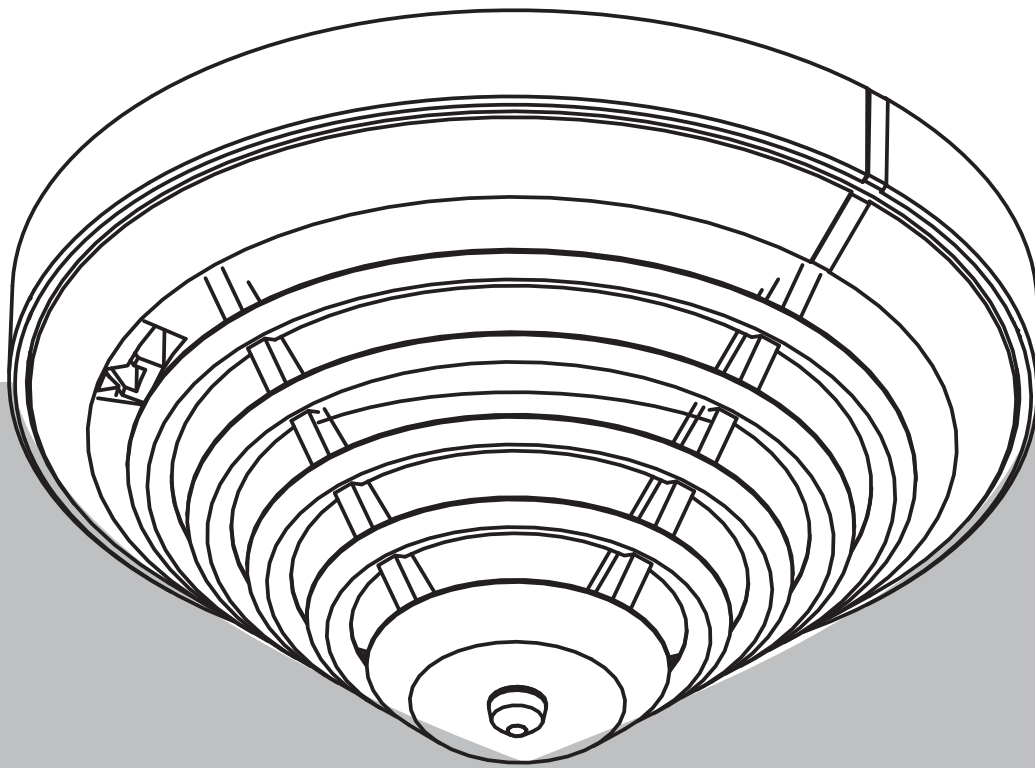

Table of contents

1	Product Description	5
2	System Overview	7
2.1	System Description	7
2.2	Functional Description of the Sensor Technology	7
2.2.1	Optical Sensor (Smoke Detector)	7
2.2.2	Thermal Sensor (Heat Detector)	8
2.2.3	Chemical Sensor (Gas Sensor)	8
2.3	Two-color LED	8
2.4	Features	8
2.5	Compatibility	9
2.6	Accessories	9
2.6.1	Detector bases	9
2.6.2	Detector Base Sounders	11
2.6.3	Acoustic/visual alarms	11
2.6.4	Remote Indicators	11
2.6.5	End-of-line modules	12
2.6.6	Mounting and protection accessories	13
3	Basic installation and configuration notes	15
4	Programming	16
4.1	FAP-425-DOTC-R and FAP-425-DOTCO-R	16
4.2	FAP-425-DOT-R / FAP-425-OT-R / FAP-425-OT	18
4.3	FAP-425-DO-R / FAP-425-O-R / FAP-425-O	19
4.4	FAH-425-T-R	20
5	Connection	21
5.1	Installing the Base	21
5.2	Connection	21
5.2.1	Connecting the MS 400/MS 400 B	22
5.2.2	Connecting the FAA-MSR 420	22
5.3	Installation of the detector head	23
5.4	Detector removal	24
5.5	Address setting	24
5.6	Installing Remote Indicators	25
6	Order Information	29
6.1	Detector Variants	29
6.2	Detector Bases	29
6.3	Detector Accessories	29
6.4	Installation Accessories	30
6.5	Detector Base Sounders	30
6.6	Remote Indicators	31
6.7	Service accessories	31
7	Maintenance and Service	32
7.1	Detector Type Encoding	33
7.2	Test instructions	33
7.2.1	Test instructions for detectors with optical sensor	33
7.2.2	Test instructions for chemical and thermal sensor	34
7.3	Diagnostic data	34
7.4	Warranty	36
7.5	Repair	36

7.6	Disposal	36
8	Technical Data	37

1 Product Description

AVENAR detector 4000 combines standard detection procedures such as scattered light and temperature measurement with gas measuring technology at the highest configuration level. This method uses intelligent evaluation electronics (Intelligent Signal Processing - ISP) to evaluate the signals from the smoke, thermal and chemical sensor.

Only if the signal combination corresponds to the characteristics of the area of operation, selected during the programming, the alarm is triggered automatically. Additionally the time behavior of the sensor signals is evaluated for fire and malfunction detection. Thus, for each individual sensor the reliability of detection is increased. This complex evaluation of fire characteristics (Pattern matching of fire characteristics) reduces the risk of a false alarm. Active adjustment of the response threshold of the optical or of the chemical sensor takes place (drift compensation). Adjustment to extreme disturbance variables is possible through manual or time-controlled switch-off of individual sensors.

Multi-sensor fire detectors using a combination of smoke, carbon monoxide (CO) and heat sensors can be used to achieve a high stability against deceptive phenomena and a response to a broad range of fires. The combined information collected by the multi-sensor detectors offers further areas of application.

AVENAR detector 4000 is available in different versions of single-sensor and multi-sensor detectors.

All detectors of the AVENAR detector 4000 series are suitable as a technical measure to avoid false alarms.

AVENAR detector 4000 is suitable for surface and flush cable mounting and includes separate mounting points for dropped ceiling and concealed sockets.

Standards

All devices fulfill EN 54-17: Short-circuit isolators.

Identifier	Description	Category	Standard
FAP-425-O	Optical smoke detector, automatic address setting only	Single sensor	EN 54-7
FAP-425-O-R	Optical smoke detector, automatic and manual address setting	Single sensor	EN 54-7
FAP-425-OT	Combined optical and thermal smoke detector, automatic address setting only	Multi-sensor	EN 54-5, EN 54-7
FAP-425-OT-R	Combined optical and thermal smoke detector, automatic and manual address setting	Multi-sensor	EN 54-5, EN 54-7
FAP-425-DO-R	Dual-optical smoke detector, automatic and manual address setting	Double sensor	EN 54-7
FAP-425-DOT-R	Combined dual-optical and thermal smoke detector, automatic and manual address setting	Multi-sensor	EN 54-5, EN 54-7, EN 54-29
FAP-425-DOTC-R	Combined dual-optical, thermal and chemical smoke detector, automatic and manual address setting	Multi-sensor	EN 54-5, EN 54-7, EN 54-29

Identifier	Description	Category	Standard
FAP-425-DOTCO-R	Combined dual-optical, thermal and chemical (CO gas) detector, automatic and manual address setting	Multi-sensor	EN 54-5, EN 54-7, EN 54-29, EN 54-26, EN 54-30, EN 54-31
FAH-425-T-R	Thermal detector, automatic and manual address setting	Single sensor	EN 54-5

2 System Overview

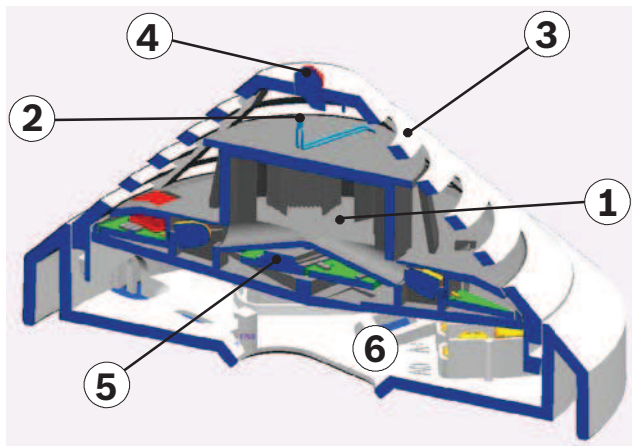

Figure 2.1: Detector set-up

1	Smoke measurement chamber with optical sensor	4	Individual display
2	Thermal sensor	5	PC board with evaluation electronics
3	Chemical sensor (covered on the cross-section)	6	Detector Base

2.1 System Description

Up to three characteristics are integrated in the detector variants of AVENAR detector 4000:

- Optical (for smoke): O
- Dual-optical (for smoke): DO
- Thermal (for heat): T
- Chemical (for CO gas): C

Rotary switches (R) enable automatic or manual address setting: FAP-425-O and FAP-425-OT are not fitted with rotary switches, but FAP-425-O-R and FAP-425-OT-R are fitted with rotary switches.

The individual sensors are programmed via the LSN network manually via the FSP-5000-RPS programming software. All sensor signals are analyzed continually by the internal signal analysis electronics (ISP) and are linked with each other. By linking the sensors (combined detectors), the detector can also be used in places where the work carried out gives rise to light smoke, steam or dust. If a signal combination fits the selected identifier for the area of operation for the detectors, an alarm is triggered automatically.

In order to adapt its sensitivity to the set threshold value the LSN improved detector monitors and adjusts itself permanently throughout its life cycle.

A message is sent to the fire panel if the detector becomes too contaminated.

2.2 Functional Description of the Sensor Technology

2.2.1 Optical Sensor (Smoke Detector)

This optical sensor utilizes the scattered-light method.

An LED sends light into the measuring chamber, where it is absorbed by the labyrinth structure. In the event of a fire, smoke enters the measuring chamber. The light is scattered by the smoke particles and hits the photo diode, which transforms the quantity of light into a proportional electrical signal.

The DO detectors have a dual optical sensor that uses the different infrared and blue light wavelengths (Dual Ray technology). This allows fires to be detected early and even the smallest quantities of smoke (TF1, TF9) to be reliably detected.



Notice!

The dual-optical detectors make an alarm decision based on an intelligent combination of the following criteria:

- Amount of smoke density measured

- Speed of smoke density increase

- Size of smoke particles (as measured by Dual Ray technology)

2.2.2

Thermal Sensor (Heat Detector)

A thermistor in a resistance network is used as a thermal sensor; an analog-digital converter measures the temperature-dependent voltage at regular intervals.

Depending on the specified category, the thermal sensor triggers the alarm status when the maximum temperature of 54 °C or 69 °C is exceeded (thermal maximum), or if the temperature rises by a defined amount within a specified time (thermal differential).

2.2.3

Chemical Sensor (Gas Sensor)

The chemical sensor detects mainly the carbon monoxide (CO) that a fire produces. The chemical sensor also detects hydrogen (H) and nitrogen monoxide (NO).

The underlying measurement principle is CO oxidation and the measurable current that it creates. The sensor signal value is proportional to the concentration of gas.

The chemical sensor gives additional information. Therefore the chemical sensor is essential to suppress disturbance variables reliably.

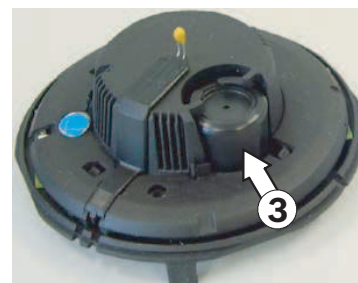

Chemical sensor

CO fire sensors can react promptly to smoldering fires. In many cases they are better suited to applications where other fire detection techniques are prone to false alarms. As a result, CO-detection helps to support an even more reliable fire detection and leads in parallel to a higher false alarm stability. This behavior is described in the guidelines EN 54-26, EN 54-30, EN 54-31.

2.3

Two-color LED

The LSN improved detector has one centrally positioned two-color LED that flashes red when indicating an alarm. When the alarm is canceled through the fire panel, then the detector returns to its operating condition.

In operating condition the LED is off by default. Showing the operating condition can be enabled with FSP-5000-RPS. Then, the LED flashes green to indicate the operating condition.

2.4

Features

- Active self-monitoring of the sensors, with display on the fire panel:

- Active adjustment of the threshold (drift compensation) if the optical sensor becomes contaminated.
- Active adjustment of the threshold (drift compensation) of the chemical sensor.
- At up to 50 V/m, the EMC is significantly higher than the normative requirements.
- Preservation of LSN loop functions in the event of wire break or short-circuit of a detector through integrated isolators.
- Individual detector identification on the fire panel in the event of an alarm. Alarm indication on the detector with a flashing red LED.
- Programmable sensitivity, i.e. can be adjusted to the area of operation.
- Increased detection and false alarm security thanks to evaluation of the temporal behavior of fire and of disturbance variables.
- Activation of a remote indicator is possible.
- To prevent that unauthorized persons have access to the device, the locking clip can be activated.
- Dust-resistant labyrinth and cap construction.
- The chamber maid plug (a cleaning opening with a plug) is for blowing out the optical chamber with compressed air. (Not required for the FAH-425-T-R Heat detector.)
- Use of shielded or unshielded cables permitted.
- The LSN improved version line technology supports the connection of up to 254 AVENAR detector 4000 series detectors per loop or stub (please observe national regulations in this regard).
- Flexible network structures without additional elements are possible (T-tapping is not feasible with detector versions without rotaries).
- Automatic or manual detector addressing selectable.
- Status information and extensive diagnostic data (e.g. serial number, operating hours, contamination level, EMC strength, current analog values) is available on fire panel screen and via Condition Monitoring.
- Compliant with EN 54, EN 50131 and VdS guidelines.

2.5 Compatibility

- For connecting to fire panels with extended range of LSN features.
- In classic mode, it can be connected to BZ 500 LSN, UEZ 2000 LSN and UGM 2020 LSN and to other panels or their receiver modules with identical connection properties but with the existing LSN system limits.

**Notice!**

The dual-optical detectors of the AVENAR detector 4000 series cannot be used with the FPA-5000 type A panel controller.

**Notice!**

FAP-425-DOTCO-R is supported on AVENAR panel 8000 and AVENAR panel 2000 only.

2.6 Accessories

2.6.1 Detector bases

Detectors in the AVENAR detector 4000 series are operated in one of the following detector bases.

The detector bases are suitable for surface mounting or for flush mounting. There are separate fixing points for ceiling-mount boxes and for flush-mount boxes. They also fit all common bore patterns.

The bases are made from white ABS plastic (color similar to RAL 9010) and have a matte surface finish.

The bases have screw terminals for connection of the detector and its accessories to the fire panel. Contacts connected with the terminals guarantee a secure electrical connection when installing the AVENAR detector 4000 Heat detector. Cable diameters of up to 2.5 mm² can be used.

The detector head can be secured against unauthorized removal with a locking clip.

MS 400

MS 400 is the standard detector base. It has seven screw terminals.



MS 400 B

MS 400 standard detector base with Bosch-branding.



FAA-MSR 420

FAA-MSR 420 is a detector base with a change-over contact relay (type C).

FAA-MSR 420 Detector base with relay is for connecting to fire panels with LSN improved technology.



FAA-420-SEAL

In damp rooms you can supplement the MS 400, MS 400 B and FAA-MSR 420 detector bases with FAA-420-SEAL. The damp room seal is made of TPE and prevents condensing water from entering the detector.



MSC 420

MSC 420 Base extension with damp room seal is designed for surface-mounted cable feed via cable protection conduits. It has two opposing pre-cut entry points of 20 mm diameter and two additional opposing and prepared entry points for diameters up to 28 mm.

MSC 420 has a diameter of 120 mm and a height of 36.7 mm. To protect against condensed water penetration, a seal is placed on the bottom of the MSC 420.



2.6.2

Detector Base Sounders

Detector base sounders are used if acoustic alarm signaling is required directly at the fire source.

FNM-420U-A-BS

Uninterruptible analog addressable base sounders for indoor use, white or red: FNM-420U-A-BSWH, FNM-420U-A-BSRD



FNM-420-A-BS

Analog addressable base sounders for indoor use, white or red: FNM-420-A-BS-WH, FNM-420-A-BS-RD



2.6.3

Acoustic/visual alarms

Uninterruptible analog addressable combination of base sounder (EN 54-3) and visual alarm (EN 54-23) for indoor use.

White housing, white or red flash: FNX-425U-WFWH, FNX-425U-RFWH

Red housing, white or red flash: FNX-425U-WFRD, FNX-425U-RFRD



2.6.4

Remote Indicators

The remote indicator is used when the automatic detector is installed in a place hidden or not visible, like in closed rooms, false ceilings or walls. It is recommended to mount the remote indicator in corridors or access pathways of the corresponding building sections or rooms.

FAA-420-RI-ROW

For applications where the automatic detector is not visible, or mounted in false ceilings/floors.



FAA-420-RI-DIN

For applications where the automatic detector is not visible, or mounted in false ceilings/floors. This version complies with DIN 14623.

**2.6.5****End-of-line modules****FLM-420-EOL4W-S**

The FLM-420-EOL4W-S is a 4 wire EOL module.

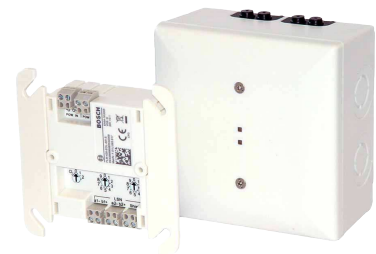
**FLM-420-EOL4W-D**

The FLM-420-EOL4W-D is a 4 wire EOL module.

**FLM-420-EOL2W-W**

The FLM-420-EOL2W-W is a 2 wire EOL module.

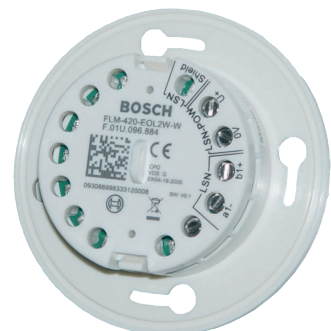

2.6.6 Mounting and protection accessories

Support Plates

The support plates are made from 1.8 mm thick ABS plastic and are clamped between the detector base and the ceiling.

TP4 400 Support Plate

The TP4 400 Support Plate is intended for an installation height up to 4 m and is designed for labels up to a size of approx. 65 x 34 mm.

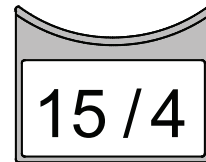

TP8 400 Support Plate

The TP8 400 Support Plate is intended for an installation height up to 8 m and is designed for labels up to a size of approx. 97 x 44 mm.

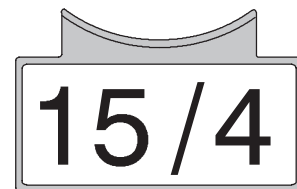

SK 400 Protective Basket

The SK 400 Protective Basket is installed over the detector and gives the detector substantial protection against damage.

If the detector is mounted in a sports facility, for example, the protective basket prevents balls or other sports equipment from hitting the detector and damaging it.



SSK 400 Protective Dust Cover

The SSK 400 Protective Dust Cover is necessary during construction work to protect an installed detector base, with or without detector module, from contamination. The protective dust cover made of polypropylene (PP) is pushed onto the installed detector base.

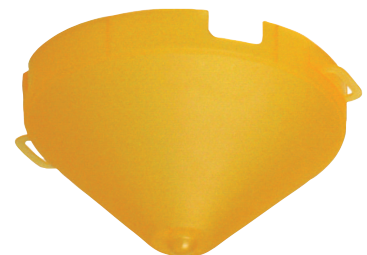

WA400 Wall bracket

The WA400 Wall bracket is used to install detectors above door frames or similar in compliance with DIBt.

The bracket is supplied with a pre-mounted detector base (the detector shown is not included in the scope of delivery).



MH 400 Detector Heating Element

The MH 400 Detector Heating Element is required if the detector is used in an environment where water condensation can occur, such as in a warehouse that must frequently be opened briefly for delivery vehicles.

The detector heating element is connected to the + V/0 V terminals in the detector base.

Operating voltage: 24 V DC

Resistance: 1 k Ω

Maximum power dissipation: 3 W.

The heating is supplied with power either by the fed-through supply voltage via the central unit or by a separate power pack.

With supply via the central unit, the number of detector heating elements depends on the cable diameter and line length used.



3 Basic installation and configuration notes

- Multi-sensor fire detectors must be planned in line with the guidelines for optical detectors until a guideline for their planning is developed in collaboration with the VdS (see also DIN VDE 0833 Part 2 and VDS 2095):
 - Maximum monitoring area 120 m².
 - Maximum installation height 16 m.
- If occasional switch-off of the optical sensor is required, the planning must occur according to the guidelines for heat detectors (see DIN VDE 0833 Part 2 and VDS 2095):
 - Maximum monitoring area 40 m².
 - Maximum installation height 7.5 m.
- Maximum permissible air speed: 20 m/s.
- FAH-425-T-R detectors must be configured according to category A1R when planning fire barriers conforming to DIBt.

**Notice!**

AVENAR detector 4000 Automatic Fire Detectors are not designed for exterior use.

**Notice!**

Planning must take the anticipated total current and line resistance into account to ensure each detector has an operating voltage of at least 15 V DC.

**Notice!**

Operating temperature

When using AVENAR detector 4000 in combination with AVENAR all-in-one 4000 consider the operation temperature of -10 to +55°C.

4 Programming

Programming occurs via a PC or laptop connected to the fire panel with FSP-5000-RPS (Remote Programming System) for panels with LSN improved version line technology. AVENAR detector 4000 is programmed by entering the area of operation. The selection of the area of operation determines the optimum characteristic field for fire and disturbance variable evaluation.

The operating mode can be changed for FAP-425-OT-R|FAP-425-OT, as well as for FAP-425-DOTC-R|FAP-425-DOTCO-R and FAP-425-DOT-R, i.e. individual sensors can be switched off:

- Switch to optical (O sensor sensitivity = low, T sensor = switched off)
- Switch to thermal differential (T sensor sensitivity = A2R, O sensor = switched off)
- Switch to thermal maximum (T sensor sensitivity = A2S, O sensor = switched off).

In the case of the purely optical FAP-425-O-R|FAP-425-O and FAP-425-DO-R detectors, the sensitivity of the optical sensor can be set to three levels. Depending on the operating location, the optical sensor in the detector is thus adjusted to the environmental conditions.

Notice!



For fire detection, the purely optical detector also evaluates the time behavior of the fire characteristics, which differs significantly from the time behavior of disturbance variables and that occurring during a detector test.

As a result, there are also different trigger times when testing with a test aerosol outside of Walk test operation (10 s to max 60 s), depending on the selected sensitivity adjustment.

FAH-425-T-R is programmed by taking into account the ambient temperature, the installation height and the category as per EN 54 Part 5.

Programming of the optical, thermal, and chemical sensors and the linking of all sensors via algorithms significantly increases the detection ability and security against false alarms.

4.1 FAP-425-DOTC-R and FAP-425-DOTCO-R



Notice!

The default setting of FAP-425-DOTC-R and FAP-425-DOTCO-R in FSP-5000-RPS is **Hotel room/smoker room**.

Installation location	Detector type	Sensitivity			Standard
		Temperature (T)	Optical (O)	Chemical (C)	
Office after hours	O, T _{max} , T _{diff} , C	High (A2R)	High	High	EN 54-5, EN 54-7, EN 54-29
Hotel room/smoker room = default setting	O, T _{max} , T _{diff} , C	High (A2R)	Low*	Low	EN 54-5, EN 54-7
Office day mode	O, T _{max} , T _{diff} , C	Low (BR)	Medium	High	EN 54-5, EN 54-7, EN 54-29
Server room	O, T _{max} , T _{diff} , C	High (A2R)	High	High	EN 54-5, EN 54-7, EN 54-29
Production location	O, T _{max} , T _{diff} , C	Low (BR)	Low*	Medium	EN 54-5, EN 54-7
Garage	O, T _{max} , T _{diff} , C	High (A2R)	Low*	Low	EN 54-5, EN 54-7

Installation location	Detector type	Sensitivity			Standard
		Temperature (T)	Optical (O)	Chemical (C)	
Warehouse without combustion-engine traffic	O, T _{max} , T _{diff} , C	Low (BR)	High	High	EN 54-5, EN 54-7, EN 54-29
Conference room/waiting room/exhibition hall	O, T _{max} , T _{diff} , C	High (A2R)	Low*	Medium	EN 54-5, EN 54-7
Kitchen/casino/restaurant	O, T _{max} , C	Low (BS)	Low*	Low	EN 54-5, EN 54-7
Warehouse with combustion-engine traffic	O, T _{max} , T _{diff} , C	Low (BR)	Low*	Low	EN 54-5, EN 54-7
Thermal sensor: fixed and rate-of-rise temperature	T _{max} , T _{diff}	High (A2R)	-	-	EN 54-5
Optical sensor	O	-	Low	-	-
Thermal sensor: fixed temperature	T _{max}	High (A2S)	-	-	EN 54-5
Optical and CO sensor	O, C	-	Low	High	-
School/kindergarten	O, T _{max} , T _{diff} , C	High (A2R)	Medium	High	EN 54-5, EN 54-7, EN 54-29
Theater/concert hall	O, T _{max} , T _{diff} , C	High (A2R)	Medium	High	EN 54-5, EN 54-7, EN 54-29
Optical + thermal + CO sensor: high sensitivity**	O, T _{max} , T _{diff} , C	High	High	High	EN 54-31
Optical + thermal + CO sensor: low sensitivity**	O, T _{max} , T _{diff} , C	Low	Medium	High	EN 54-31
Thermal and CO sensor***	T _{max} , T _{diff} , C	Low	-	High	EN 54-30
CO sensor***	C	-	-	High	EN 54-26

O = optical sensor, T_{max} = thermal maximum unit, T_{diff} = thermal differential unit, C = chemical sensor

* If optical sensor sensitivity is low, the detector will only trigger if smoke as well as an increase in CO concentration or temperature is detected.

** Suppression of single fire phenomena, only available for FAP-425-DOTCO-R

*** only available for FAP-425-DOTCO-R

4.2 FAP-425-DOT-R / FAP-425-OT-R / FAP-425-OT



Notice!

The default setting of FAP-425-DOT-R, FAP-425-OT-R and FAP-425-OT in FSP-5000-RPS is **Office day mode**.

Installation location	Detector type	Sensitivity		Standard
		Temperature (T)	Optical (O)	
Office after hours	O, T _{max} , T _{diff}	High (A2R)	High	EN 54-5, EN 54-7, EN 54-29 (FAP-425-DOT-R only)
Hotel room/smoker room	O, T _{max} , T _{diff}	High (A2R)	Low	EN 54-5, EN 54-7
Office day mode = default setting	O, T _{max} , T _{diff}	Low (BR)	Medium	EN 54-5, EN 54-7, EN 54-29 (FAP-425-DOT-R only)
Server room	O, T _{max} , T _{diff}	High (A2R)	High	EN 54-5, EN 54-7, EN 54-29 (FAP-425-DOT-R only)
Production location	O, T _{max} , T _{diff}	Low (BR)	Low	EN 54-5, EN 54-7
Garage – FAP-425-OT-R, FAP-425-OT – FAP-425-DOT-R	T _{max} , T _{diff} O, T _{max} , T _{diff}	High (A2R) High (A2R)	- Low	EN 54-5 EN 54-5, EN 54-7
Warehouse without combustion-engine traffic	O, T _{max} , T _{diff}	Low (BR)	High	EN 54-5, EN 54-7, EN 54-29 (FAP-425-DOT-R only)
Conference room/waiting room/exhibition hall	O, T _{max} , T _{diff}	High (A2R)	Low	EN 54-5, EN 54-7
Kitchen/casino/restaurant	T _{max}	Low (BS)	-	EN 54-5
Warehouse with combustion-engine traffic	O, T _{max} , T _{diff}	Low (BR)	Low	EN 54-5, EN 54-7
Thermal sensor: fixed and rate-of-rise temperature	T _{max} , T _{diff}	High (A2R)	-	EN 54-5
Optical sensor	O	-	Low	-
Thermal sensor: fixed temperature	T _{max}	High (A2S)	-	EN 54-5
School/kindergarten	O, T _{max} , T _{diff}	High (A2R)	Medium	EN 54-5, EN 54-7, EN 54-29 (FAP-425-DOT-R only)
Theater/concert hall	O, T _{max} , T _{diff}	High (A2R)	Medium	EN 54-5, EN 54-7, EN 54-29 (FAP-425-DOT-R only)

O = optical sensor (dual-optical in FAP-425-DOT-R detectors), CO = chemical sensor (for CO gas)
T_{max} = thermal maximum unit, T_{diff} = thermal differential unit

4.3

FAP-425-DO-R / FAP-425-O-R / FAP-425-O

**Notice!**

The default setting of FAP-425-DO-R, FAP-425-O-R and FAP-425-O in FSP-5000-RPS is **Medium**.

Installation location	Sensitivity
Office after hours	High
Hotel room/smoker room	Low
Office day mode	Medium
Server room	High
Production location	Low
Warehouse without combustion-engine traffic	High
Conference room/waiting room/exhibition hall	Low
School/kindergarten	Medium
Theater/concert hall	Medium
Warehouse with combustion-engine traffic	Low

4.4 FAH-425-T-R



Notice!

EN 54 Part 5

The default setting of FAH-425-T-R in FSP-5000-RPS is **A2R**.

Sensitivity	Description
A2R	Typical application temperature: 25 °C, $T_{max} + T_{diff}$, height up to 6 m
A2S	Typical application temperature: 25 °C, only T_{max} , height up to 6 m
A1R	Typical application temperature: 25 °C, $T_{max} + T_{diff}$, height 6 m to 7.5 m
A1	Typical application temperature: 25 °C, only T_{max} , height 6 m to 7.5 m
BR	Typical application temperature: 40 °C, $T_{max} + T_{diff}$, height up to 6 m
BS	Typical application temperature: 40 °C, only T_{max} , height up to 6 m

Categories as per EN 54 Part 5

With the detector types FAH-425-T-R, it is possible to set one of the categories listed above in line with planning.

In the categories A1, A2S and BS, the FAH-425-T-R is operated purely as a thermal maximum detector. In this case, the detector does not activate at below 54 °C in category A2S, and not below 69 °C in category BS.

The categories A2S and BS are therefore particularly suitable for applications where higher temperature rates-of-rise occur over a longer period, e.g. in kitchens or boiler rooms.

The categories A1R, A2R and BR indicate that the thermal differential unit is active in addition to the thermal maximum unit.

These categories are especially well-suited for use in unheated buildings where the ambient temperature can vary greatly but high temperature rates-of-rise do not last long.

The thermal differential unit enables categories A1R/A2R detectors to respond at $T < 54$ °C and category BR detectors at $T < 69$ °C.

The selection of the category also depends on the installation height of the detector.

To maintain the greatest possible security against false alarms, categories A1 and A1R should not be selected for room heights below 6 m, although these categories are in theory permitted. Furthermore, the expected application temperature must be taken into consideration.

Temperature rate-of-rise [K min ⁻¹]	Response time for detectors in the category A1R		Response time for detectors in the category A2R/BR	
	Lower limiting value [min/sec]	Upper limiting value [min/sec]	Lower limiting value [min/sec]	Upper limiting value [min/sec]
10	1 min	4 min 20 s	2 min	5 min 30 s
20	30 s	2 min 20 s	1 min	3 min 13 s
30	20 s	1 min 40 s	40 s	2 min 25 s

5 Connection

5.1 Installing the Base

The detector bases are screwed to the even, dry surface using two screws approx. 55 mm apart.

To feed cables through for surface mounting, punch out the prepared entry points (X) on the housing.

For flush-mounted cable insertion, feed the cable through the opening in the middle of the base.

The long holes marked in the sketch with "Y" are intended for base installation in a flush mount back box and should only be used for this purpose.



Notice!

Cables can be fed in and out on the same side.

On the FAA-420-SEAL and MSC 420, punch out the integrated seal with a sharp tool. Do not cut with a knife.

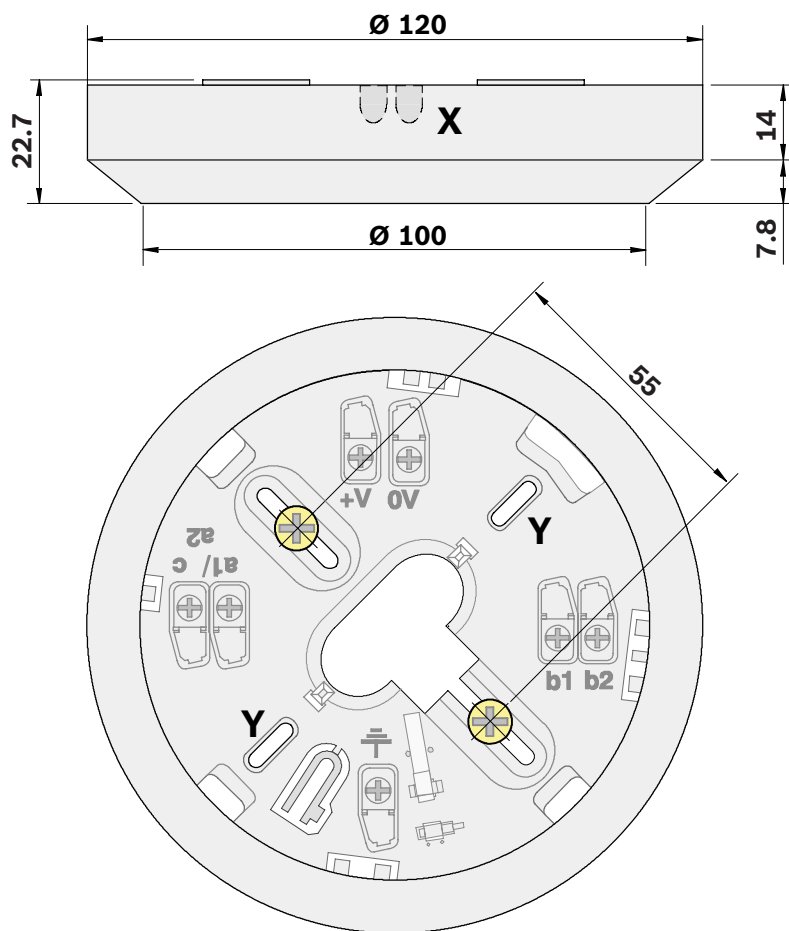

5.2 Connection



Notice!

Keep shield wire as short as possible and insulate.

5.2.1

Connecting the MS 400/MS 400 B

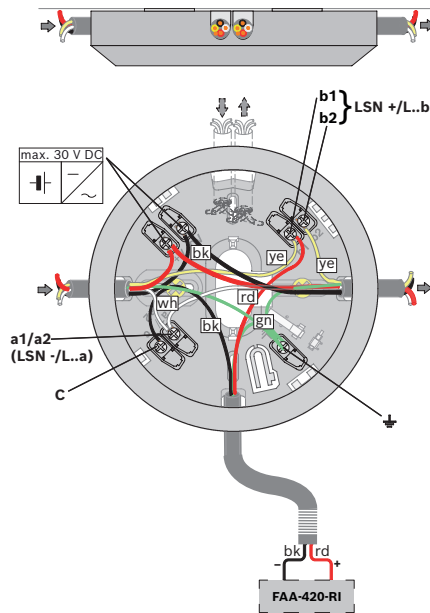

ye	Yellow, connection to b1/b2 (LSN +)
wh	White, connection to a1/a2 (LSN -)
rd	Red, connection to +V
bk	Black, connection to 0V
gn	Green, connection to shield wire
c	Indicator output
+V/0 V	Terminals for looping through the supply voltage for downstream elements
FAA-420-RI	Remote indicator

**Notice!**

When using unshielded cables for the connection of the remote indicator, the maximum cable length is 3m. No limitation when using shielded cables.

5.2.2

Connecting the FAA-MSR 420

Maximum contact load (resistive load) of the change-over contact relay:

- 62.5 VA: 0.5 A at 125 V AC
- 30 W: 1 A at 30 V DC

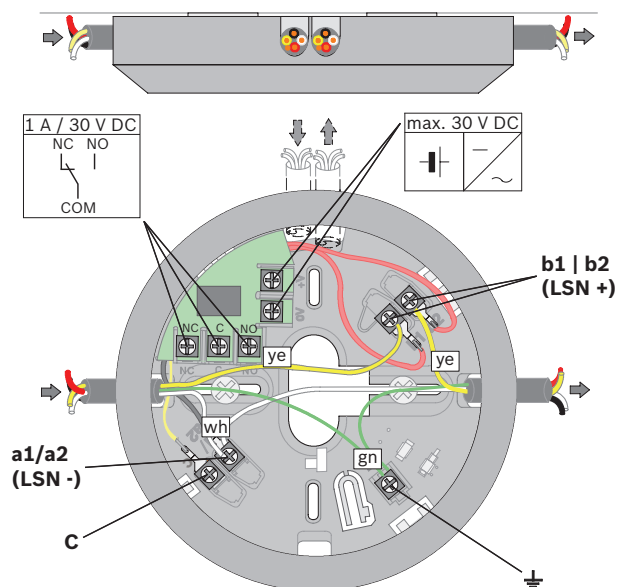

ye	Yellow, connection to b1/b2 (LSN +)
wh	White, connection to a1/a2 (LSN -)
gn	Green, connection to shield wire
NC/C/NO	Change-over contact relay
+V/0 V	Terminals for looping through the supply voltage for downstream elements

5.3 Installation of the detector head



Notice!

The packaging for the multisensor detector with C sensor consists of tear-proof PE-ALU laminated film and must be cut open carefully.

After installation and connection of the base, the detector head is set into the base and turned to the right as far as it will go.

Detector bases are delivered with an inactive locking clip.

To protect against removal, the detector head can be locked in the base. To do so, break the locking clip (X) out of the base and push it into the corresponding guide.

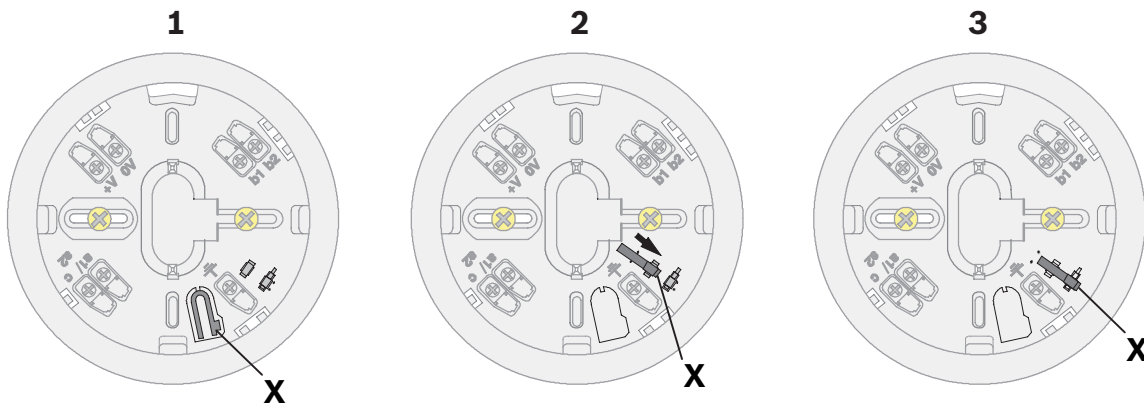

Figure 5.1: Activation of locking clip

1	Locking clip (X) before breaking out.
3	Locking clip (X) fitted, but deactivated.
5	Locking clip activated

5.4 Detector removal

Unlocked detector heads are disassembled by turning them to the left and removing them from the base.

Locked detector heads are disassembled by inserting a screwdriver into the unlocking opening (Y). At the first time removing the detector, push the screwdriver hard through the plastic to get to the locking clip. Push the screwdriver upward and turn the detector to the left at the same time.

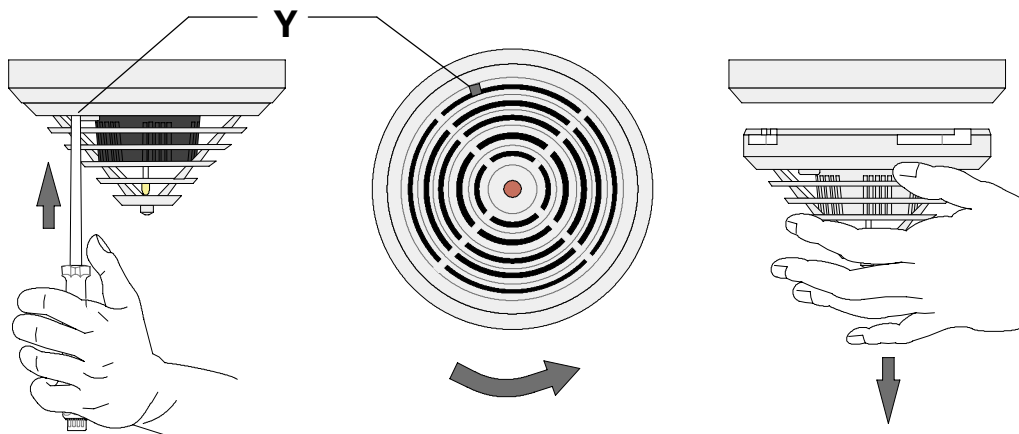

Figure 5.2: Detector removal (locked detector head)

5.5 Address setting

The versions for automatic and manual address setting have three rotary switches on the bottom of the detector. Use the rotary switches to select automatic address setting or manual address setting with or without auto-detection. The versions without rotaries are automatically addressable only.

The following settings are possible:

Rotary switch setting	Address	Operating mode
	0 0 0	Loop/stub with LSN improved version mode and with automatic address setting (T-tapping not possible) = delivery status
	0 0 1 ... 2 5 4	Loop/stub/T-tapping with LSN improved mode and with manual address setting (address shown in example = 131)
	CL 0 0	Loop/stub in classic LSN mode with automatic address setting (T-tapping not possible, maximum number of elements = 127)

Move the rotary switches to the required position using a slotted-head screwdriver.

Automatic address allocation

If addresses are automatically allocated by a fire panel with LSN improved version technology, all detectors must have the address "0 0 0" (delivery status).

For connection to classic LSN fire panels (BZ 500 LSN, UEZ 2000 LSN, UGM 2020), all detectors must have the address "CL 0 0".

Manual address setting

For manual address setting, the detector address is set with the three rotary switches. The right-hand rotary switch is used to set the units, the central rotary switch is used to set the tens and the left-hand rotary switch is used to set the hundreds.



Notice!

It is not permissible to use addresses greater than 254.

This will prompt the display of an error message on the fire panel.

All the detectors in a loop, stub or T-tap must have an address between 1 and 254 when addressed manually.

From LSN module software version 1.0.35, you can operate LSN improved and LSN classic elements together in one loop or stub. If an LSN classic element is present, only 127 elements can be used in the loop.

Please note that only loop or stub structures can be used for configurations with mixed LSN classic and LSN improved elements.

5.6 Installing Remote Indicators

Installation of the FAA-420-RI Remote Indicator

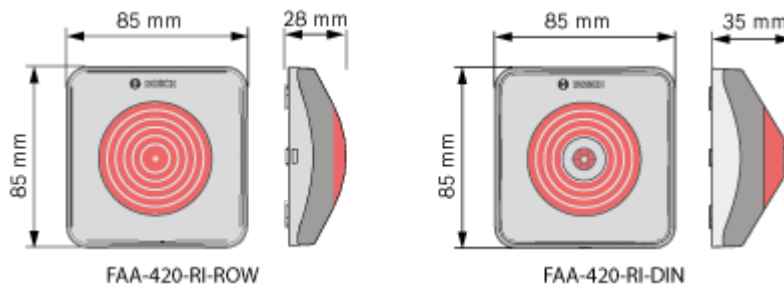



Warning!

Malfunction and Damage

If maximum current feed of the connected detector is larger than 30 mA, it can result in malfunction and damage to the remote indicator.

- a) Ensure, that the maximum current feed of 30 mA is not exceeded
- b) Use point-type automatic Bosch detectors, which have an internal resistor that limits the current consumption.

Before assembly remove the cap from the base plate

1. Unlock the snap-fit hook by pressing on it with a flat object and lift the cap carefully
2. Remove the connection board for easy access.
3. Mount the base plate directly on a dry, level surface with two or four screws.

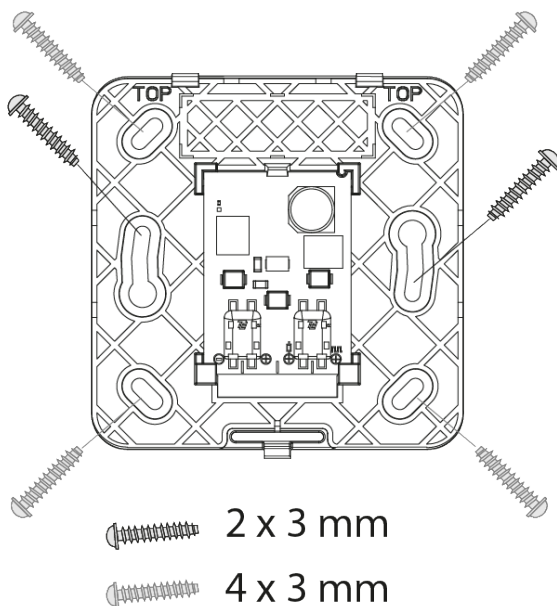

1. For surface-mounted cables, break out the prepunched cable entries.

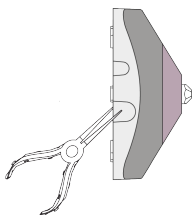

2. For flush-mounted cables, insert the cable through the opening under the connection board.

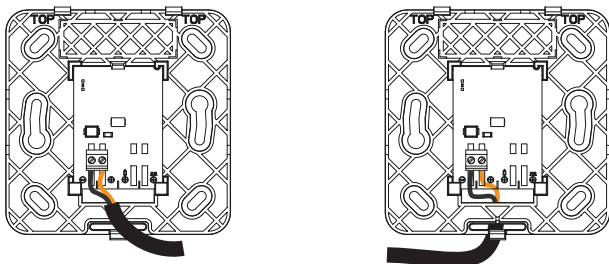

3. Secure the cable with a zip tie on the base plate.

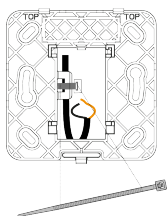

Technical specifications

	FAA-420-RI-ROW	FAA-420-RI-DIN
Operating Voltage	depends on current feed	<ul style="list-style-type: none"> - Operating mode 1: depends on current feed - Operating mode 2: 8,5 to 33 V DC - Operating mode 3: 11 to 33 V DC
Current feed	3 to 30 mA	<ul style="list-style-type: none"> - Operating mode 1: 3 to 30 mA - Operating mode 2: 11 to 14 mA - Operating mode 3: 3 mA
Permissible wire gauge	0,4 - 1,3 mm	0,6 - 1,0 mm
Display medium	1 LED	1 LED
Dimensions	85 x 85 x 28 mm	85 x 85 x 35 mm
Weight	45 g	65 g

FAA-420-RI-DIN



Warning!

Malfunction and Damage

Note the maximum permitted current supply respectively the input voltage range of the functional modes.

► Wire the remote indicator as shown.

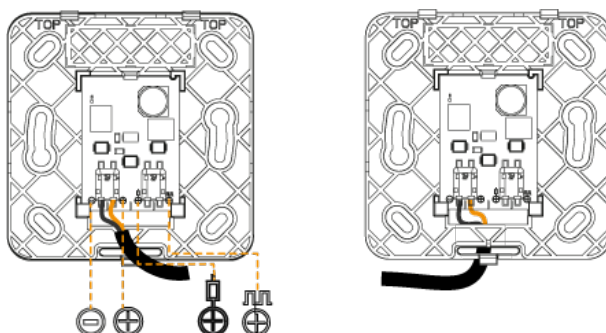

Mode	Terminal connection	Alarm condition
1		The remote indicator shows steady red light.

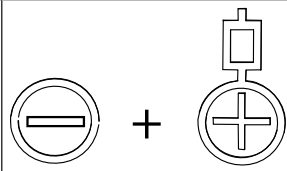
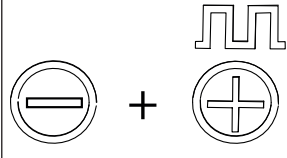
Mode	Terminal connection	Alarm condition
2		The remote indicator shows steady red light.
3		The remote indicator shows flashing red light.

Operate in mode 1 and 3 only, when connected to LSN detectors.

1. Place the cap on the base plate in such a way that the two hooks are inserted into the slits.
2. Press the cap lightly onto the base plate until the snap-fit-hook engages.

Wiring

For connection to the standard bases MS400/MS400B note the following:



Notice!

When using unshielded cables for the connection of the remote indicator, the maximum cable length is 3m. No limitation when using shielded cables.

FAA-420-RI-ROW

1. Wire the remote indicator as shown.

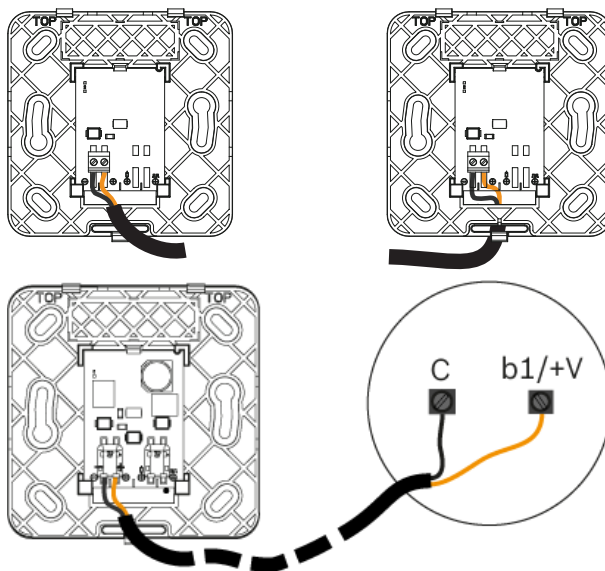

2. Place the cap on the base plate in such a way that the two hooks are inserted into the slits.
3. Press the cap lightly onto the base plate until the snap-fit-hook engages.

6 Order Information

6.1 Detector Variants

Type number	Designation	Product ID
FAP-425-O	Optical Smoke Detector, automatic address setting only	F.01U.307.725
FAP-425-O-R	Optical Smoke Detector, automatic and manual address setting	F.01U.307.726
FAP-425-OT	Multisensor Detector Optical/Thermal, automatic address setting only	F.01U.307.727
FAP-425-OT-R	Multisensor Detector Optical/Thermal, automatic and manual address setting	F.01U.307.728
FAP-425-DO-R	Dual-optical smoke detector, automatic and manual address setting	F.01U.307.729
FAP-425-DOT-R	Dual-optical, thermal multisensor detector, automatic and manual address setting	F.01U.307.730
FAP-425-DOTC-R	Dual-optical, thermal, chemical multisensor detector, automatic and manual address setting	F.01U.307.731
FAP-425-DOTCO-R	Combined dual-optical, thermal and chemical (CO gas) detector, automatic and manual address setting	F.01U.395.473
FAH-425-T-R	Heat Detector, automatic and manual address setting	F.01U.307.732

6.2 Detector Bases

Type number	Designation	Product ID
MS 400	Standard detector base, for surface-mount and flush-mount cable insertion	4.998.021.535
MS 400 B	Standard detector base, for surface-mount and flush-mount cable insertion, Bosch-branded	F.01U.215.139
FAA-MSR 420	Detector Base with Relay	F.01U.508.658
FAA-420-SEAL	Damp room seal for MS 400 and MS 400 B detector bases	F.01U.215.142
MSC 420	Additional base with damp room seal, for surface-mount cable insertion	4.998.113.025

6.3 Detector Accessories

Type number	Designation	Product ID
FLM-420-EOL2W-W	EOL Module LSN	F.01U.096.884
FLM-420-EOL4W-S	EOL Module LSN	F.01U.083.617

Type number	Designation	Product ID
FLM-420-EOL4W-D	EOL Module LSN	F.01U.083.618
TP4 400	Support Plate for Detector Identification, installation heights up to 4 m (Ordering per 50 pieces)	4.998.084.709
TP8 400	Support Plate for Detector Identification, installation heights up to 8 m (Ordering per 50 pieces)	4.998.084.710
SK 400	Protective Basket to guard against mechanical damage	4.998.025.369
SSK 400	Protective Dust Cover (1 pack= 10 pieces)	4.998.035.312
MH 400	Detector heating element	4.998.025.373

6.4 Installation Accessories

Type number	Designation	Product ID
WA400	Detector Console, for DIBt-compliant detector installation above doors or similar, incl. detector base	4.998.097.924
FMX-DET-MB	Mounting bracket, with installation material for false floors, no detector base	2.799.271.257

6.5 Detector Base Sounders

Type number	Designation	Product ID
FNM-420-A-BS-WH	Analog addressable base sounder for indoor use, white	F.01U.064.687
FNM-420-A-BS-RD	Analog addressable base sounder for indoor use, red	F.01U.064.688
FNM-420U-A-BSWH	Uninterruptible analog addressable base sounder for indoor use, white	F.01U.168.575
FNM-420U-A-BSRD	Uninterruptible analog addressable base sounder for indoor use, red	F.01U.168.576
FNX-425U-WFWH	Uninterruptible analog addressable combination of base sounder (EN 54-3) and visual alarm (EN 54-23) for indoor use, white housing, white flash.	F.01U.359.432
FNX-425U-RFWH	Uninterruptible analog addressable combination of base sounder (EN 54-3) and visual alarm (EN 54-23) for indoor use, white housing, red flash.	F.01U.359.433
FNX-425U-WFRD	Uninterruptible analog addressable combination of base sounder (EN 54-3) and visual alarm (EN 54-23) for indoor use, red housing, white flash.	F.01U.359.434
FNX-425U-RFRD	Uninterruptible analog addressable combination of base sounder (EN 54-3) and visual alarm (EN 54-23) for indoor use, red housing, red flash.	F.01U.359.435

6.6 Remote Indicators

Type Number	Designation	Product ID
FAA-420-RI-ROW	Remote indicator	F.01U.289.120
FAA-420-RI-DIN	Remote indicator for DIN application	F.01U.289.620

6.7 Service accessories

Type number	Designation	Product ID
SOLO200	Universal detector removal tool	4.998.112.113
RTL-cap	Plastic caps for the SOLO200 Detector Removal Tool (scope of delivery = 2 pieces)	4.998.082.502
SOLO330	Smoke Detector Tester	4.998.112.071
FME-SOLO-A10S	Smoke testing aerosol, 250ml	F.01U.345.557
FME-TEST-CO	CO Testing gas (250 ml)	F.01U.301.469
SOLO461	Heat Detector Test Kit	F.01U.363.162
SOLO770	Spare battery baton	F.01U.363.163
FME-TESTIFIRE	Multi-Stimulus Testing Tool	F.01U.143.407
FME-TS3	Smoke Capsule	F.01U.143.404
FME-TC3	CO-Capsule	F.01U.143.405
SOLO100	Telescopic Access Pole	4.998.112.069
SOLO101	Fixed Extension Pole	4.998.112.070
SOLO610	Test Equipment Bag	4.998.112.073

7 Maintenance and Service

In Germany, maintenance work and inspection work on security systems are governed by the regulations of DIN VDE 0833; these regulations stipulate reference to the manufacturer's instructions for maintenance intervals.

- Maintenance and inspection work should be carried out regularly and by trained personnel.
- Bosch recommends carrying out a functional and visual inspection at least once a year.

Testing	Detector Type			
	FAP-425-DOTCO-R, FAP-425-DOTC-R	FAP-425-DOT-R, FAP-425-OT-R, FAP-425-OT	FAP-425-DO-R, FAP-425-O-R, FAP-425-O	FAH-425-T-R
Check of the LED display	X	X	X	X
Visual check of the mounting	X	X	X	X
Visual check for damage	X	X	X	X
Check the monitoring range has not been restricted, for instance by shelves or similar installations.	X	X	X	X
Triggering with hot air	X	X	-	X
Triggering with Test Aerosol	X	X	X	-
Triggering with CO Testing gas	X	-	-	-

- With the FAP-425-DOTC-R, the chemical sensor has a life cycle of max. 6 years. Once the chemical sensor is switched off, this detector continues to function as a DOT or DO detector and is displayed on the panel with: EMERGENCY OPERATION
This is why FAP-425-DOTC-R detectors need to be exchanged every 5-6 years.
- With the FAP-425-DOTCO-R, the chemical sensor has a life cycle of 10 years. Once the life cycle of the chemical sensor is exceeded, the detector cannot support new sensitivity settings (for EN 54-26, EN 54-30, EN 54-31) anymore. No emergency operation is possible as CO sensing is essential for those settings.
This is why FAP-425-DOTCO-R detectors need to be exchanged after 10 years at the latest.
- Optical fire detectors should, depending on the environmental conditions, be cleaned and exchanged regularly.
In especially dusty environments, cleaning and exchange may be necessary earlier.

Every detector has a Chamber Maid Plug (cleaning opening with a plug) for blowing out the optical chamber with compressed air (not required for the Heat Detector).

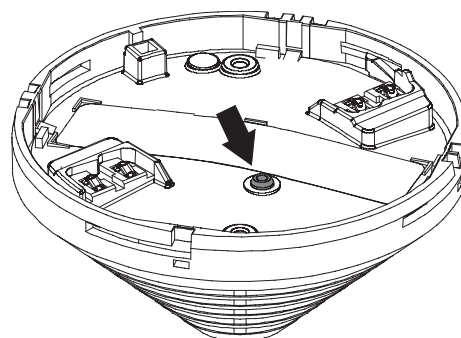

7.1 Detector Type Encoding

With the exception of the FAP-425-O-R and FAP-425-O, all detectors are fitted with a colored ring around the central individual display to identify the detector type. This facilitates inspection by service personnel.

Type number	Color code	
FAP-425-DOTCO-R	2 x pastel blue	
FAP-425-DOTC-R	2 x yellow	
FAP-425-DOT-R	2 x black	
FAP-425-OT-R FAP-425-OT	Black	
FAP-425-DO-R	2 x gray	
FAP-425-O-R FAP-425-O	-	
FAH-425-T-R	Red	

7.2 Test instructions

For fire detection, detectors use the time behavior of the fire characteristics, which deviates significantly from the time behavior of disturbance variables.

FAP-425-DOTC-R and FAP-425-DOTCO-R are equipped with an additional sensor for detecting CO in the event of a fire. The CO sensor provides improved response behavior and increased malfunction suppression in critical environmental conditions.

7.2.1 Test instructions for detectors with optical sensor

Since the behavior of the fire characteristics deviates from the time behavior of a detector check with aerosol, the detector must be switched to revision mode for a functional test.

Testing in revision mode

- On the fire panel, switch the detector zone to be inspected to revision mode. Thus the detector is set automatically into revision operation and prepared for the detector test.
- Only in walktest mode can the detector's individual sensors be made to trigger one after the other with the corresponding test device. For this, you should use the service accessories we recommend.
- The optical sensor is tested with the detector tester for smoke detectors with the test aerosol. The aerosol must be applied for 1 to 2 seconds for the smoke test.



Notice!

The test head must remain over the detector until the detector has been triggered. The distribution of the test aerosol in the transceiver and thus the trigger time of the sensor can take up to 10 seconds.

Testing outside revision mode

If you want to test detectors in controls, 2-detector or 2-group dependencies, you must test them outside the revision mode.

- FAP-425-O-R, FAP-425-O and FAP-425-DO-R: Trigger the detector with a testing aerosol. Depending on the sensitivity settings, it can take up to 1 minute till the detector activates. It is recommended to apply the aerosol in spurts (for example one short spurt of 1 second, 30 seconds of waiting, another short spurt).
- All other detector variants: Trigger the thermal sensor with the test device for heat detectors.

7.2.2

Test instructions for chemical and thermal sensor

Sequential walktest

On the fire panel, in the **Walktest** menu, select **Sequential walktest**.

- The same test device as for a optical sensor is used to test the CO sensor in the FAP-425-DOTC-R and FAP-425-DOTCO-R. Exchange the test aerosol with the CO testing gas bottle. The testing gas must be applied for 1/2 to 1 second for the CO test.



Notice!

The test head must remain over the detector until the detector has been triggered. The time taken to distribute the test aerosol in the test head and therefore the trigger time of the sensor can be up to 20 seconds.

- A thermal sensor is tested with the test device for heat detectors.

Simultaneous walktest

Multisensor detectors can be tested simultaneously with the FME-TESTIFIRE multi-stimulus test tool.

- On the fire panel, in the **Walktest** menu, select **Simultaneous walktest**. Observe the notes in the detector testing device and fire panel operating instructions.



Notice!

An alarm message is only displayed on the panel if all sensors are triggered during the simultaneous walktest. If this does not happen, one of the sensors is faulty.

Testing outside the revision mode

FAP-425-DOTC-R and and FAP-425-DOTCO-R can be triggered outside of the revision mode only by the following stimuli:

- Rise of temperature according to the sensitivity settings A2R, A2S, BR, and BS as defined by EN 54-5
- Simultaneous creation of artificial smoke and CO (by a suitable multi-stimulus test tool, like FME-TESTIFIRE)
- Simultaneous creation of artificial smoke and rise of temperature (by a suitable multi-stimulus test tool, like FME-TESTIFIRE)

7.3

Diagnostic data

- **Status:** Status of the detector: normal, trouble or alarm.
- **Type:** Detector type.
- **Physical address:** Module where the detector or the detector line is installed.
- **Logical address:** Detector installation address. Example: 10-03 means that the detector is in zone 10 and has the detector number 3.
- **Optical analog value IR LED, Optical analog value blue LED**

Optical system value (display of the current pollution level)	
0 - 230	Initial set-up value for a new detector
0 - 350	Normal working range
351 - 450	Slight pollution: Exchange detector soon
451 - 510	Heavy pollution: Exchange detector immediately
>511	O fault: optical sensor is deactivated.

– **Temperature in Celsius**

Temperature value [°C] (display of the value currently measured by the thermal sensor)	
FAH-425-T-R, FAP-425-OT-R, FAP-425-OT, FAP-425-DOT-R	-20 °C – 50 °C
FAP-425-DOTC-R, FAP-425-DOTCO-R	-10 °C – 50 °C

- The **Carbon monoxide (CO) analog value** specifies the currently measured CO concentration. The CO analog value is between 0 for a normal operating condition and the maximum value 600.
- **Operation time:** Operation time of the detector in hours starting from the initial start-up of the detector.
- **Detector state information**

Detector state information	
10000...	OK
11000...	General C malfunction. Possible causes: <ul style="list-style-type: none"> – Thermal sensor fault – The operation time of the C sensor exceeds the maximum time of operation. The T sensor and the C sensor is off. The optical sensor is still in operation. Exchange the detector immediately.
11100...	The impedance of the electrochemical cell is too high. The C sensor is off. The rest of the sensors are in operation. Exchange the detector immediately.
11010...	The operating temperature exceeds the maximum value. The C sensor is off. The rest of the sensors are still in operation.
11001...	Malfunction due to read/write error in the EEPROM. The detector is off. Exchange the detector immediately.
00000xxx	Number of read/write errors in the EEPROM.

- **Pollution level IR LED:** The optical initial set-up value for infrared wavelengths of a new detector is stored in the integrated EEPROM during the final inspection. The pollution level specifies by how much this analog value has increased in comparison with the delivery state.

- **Pollution level blue LED:** The optical initial set-up value for blue light wavelengths of a new detector is stored in the integrated EEPROM during the final inspection. The pollution level specifies by how much this analog value has increased in comparison with the delivery state.
- **ID:** The 10-digit unique number to identify the detector through diagnostic screen or Remote Services when connected to the panel.
- The **EMC value** indicates the EMC level. The current EMC value (short-term measurement) is used during or right after the installation of the detector. The average EMC value (long-term measurement) is used during the operation of the detector.

Current EMC value	Average EMC value	Description
0 - 8	0 - 49	Low EMC level. No action required.
9 - 20	50 - 79	Medium EMC level. Consider location.
>20	80 - 100	High EMC level. No suitable location.

7.4 Warranty

Defective detectors are exchanged free of charge in the case of a claim under the warranty.

7.5 Repair

In the event of a defect, exchange the entire detector.

7.6 Disposal

Unusable electrical and electronic devices or modules must not be disposed of with normal household refuse. They must be disposed of in compliance with the applicable regulations and directives (e.g. WEEE in Europe).



Packaging film for the FAP-425-DOTC-R and FAP-425-DOTCO-R

The packaging bag used for multisensor detectors with C sensor consists of tear-resistant PE-ALU laminated film and may be disposed of with the household refuse.

Defective detectors are exchanged and should be disposed of in accordance with legal regulations.

8 Technical Data

Detector overview

	FAP-425- DOTCO-R	FAP-425 -DOTC-R	FAP-425 -DOT-R	FAP-425 -DO-R	FAP-425 -OT-R	FAP-425 -OT	FAP-425 -O-R	FAP-425 -O	FAH-425 -T-R
Scattered-light measurement	X	X	X	X	X	X	X	X	-
Measurement of absolute temperature and temperature increase	X	X	X	-	X	X	-	-	X
Combustion gas measurement	X	X	-	-	-	-	-	-	-
Two optical sensors	X	X	X	X	-	-	-	-	-
Contamination detection	X	X	X	X	X	X	X	X	-
Drift compensation in the optical sensor	X	X	X	X	X	X	X	X	-
Operation mode switching/ sensor deactivation in optical unit and thermal unit	X	X	X	-	X	X	-	-	-

Electrical

Operating voltage	15 V DC to 33 V DC
Current consumption	0.55 mA
Alarm output	Per data word by two-wire signal line.
Indicator output	Open collector connects 0 V over 1.5 kΩ through, max. 15 mA.

Response sensitivity

The detector is adjustable to different sensitivity levels. Default settings are for medium sensitivity level.

	FAP-425- DOTCO-R	FAP-425 -DOTC-R	FAP-425 -DOT-R	FAP-425 -DO-R	FAP-425 -OT-R	FAP-425 -OT	FAP-425 -O-R	FAP-425 -O	FAH-425 -T-R
Optical sensor	Average < 0.15 dB/m (EN 54-7)								

	FAP-425- DOTCO-R	FAP-425 -DOTC-R	FAP-425 -DOT-R	FAP-425 -DO-R	FAP-425 -OT-R	FAP-425 -OT	FAP-425 -O-R	FAP-425 -O	FAH-425 -T-R
	Max.< 0.18 dB/m (EN 54-7)								
Thermal differential unit	EN 54-5	EN 54-5	EN 54-5	-	EN 54-5	EN 54-5	-	-	EN 54-5
Thermal maximum unit	> 54 °C / > 69 °C	> 54 °C / > 69 °C	> 54 °C / > 69 °C	-	> 54 °C / > 69 °C	> 54 °C / > 69 °C	-	-	> 54 °C / > 69 °C
Chemical Sensor	ppm range	ppm range	-	-	-	-	-	-	-

Environmental

	FAP-425- DOTCO-R	FAP-425 -DOTC-R	FAP-425 -DOT-R	FAP-425 -DO-R	FAP-425 -OT-R	FAP-425 -OT	FAP-425 -O-R	FAP-425 -O	FAH-425 -T-R
Monitoring area (m ²) (observe VdS guidelines)	120 m ²								40 m ²
Installation height (m) (observe VdS guidelines)	Max. 16 m								0 m – 7.50 m
Permissible air speed (m/s)	20 m/s								-
Storage temperature (°C)	-20 °C – 50 °C	-20 °C – 50 °C	-25 °C – 80 °C	-25 °C – 80 °C	-25 °C – 80 °C	-25 °C – 80 °C	-25 °C – 80 °C	-25 °C – 80 °C	-25 °C – 80 °C
Operating temperature (°C)	-10 °C – 50 °C	-10 °C – 50 °C	-20 °C – 50 °C	-20 °C – 65 °C	-20 °C – 50 °C	-20 °C – 50 °C	-20 °C – 65 °C	-20 °C – 65 °C	-20 °C – 50 °C
Operating relative humidity, non-condensing (%)	15% – 90%	15% – 90%	15% – 95%	15% – 95%	15% – 95%	15% – 95%	15% – 95%	15% – 95%	15% – 95%
IP rating(IEC 60529)	IP41 , IP43 with detector base and FAA-420-SEAL or MSC 420								

Mechanical

	FAP-425- DOTCO-R	FAP-425 -DOTC-R	FAP-425 -DOT-R	FAP-425 -DO-R	FAP-425 -OT-R	FAP-425 -OT	FAP-425 -O-R	FAP-425 -O	FAH-425 -T-R
Ring color code	2x pastel blue	2x yellow	2x black	2x grey	1x black	1x black	-	-	1x red
Dimensions (Ø x H) (mm) without base	Ø 99.5 mm x 52 mm								
Dimensions (Ø x H) (mm) with base	Ø 120 mm x 63.5 mm								
Material/Color	Plastic/White, similar to RAL 9010, matt finish								
LED color	Red, Green								
Weight (g)	82 g	82 g	78 g	77 g	77 g	74 g	76 g	73 g	75 g
Shipping weight (g)	122 g	122 g	112 g	111 g	111 g	108 g	110 g	107 g	109 g

Operation

FAP-425-DOTCO-R: Because of the life cycle of the CO sensor cell, detectors need to be exchanged after 10 years at the latest.

Bosch Sicherheitssysteme GmbH

Robert-Bosch-Platz 1

70839 Gerlingen

Germany

www.boschsecurity.com

© Bosch Sicherheitssysteme GmbH, 2024

Building solutions for a better life

202412171406