

1 |



0786

Bosch Sicherheitssysteme GmbH
Werner-von-Siemens-Ring 10, D-85630 Grasbrunn
10
0786 - CPD - 20926

EN 54-18:2005 + AC 2007

Eingangs-/Ausgangsgerät | Input-/Output Device
FLM-320-EOL2W

2 |

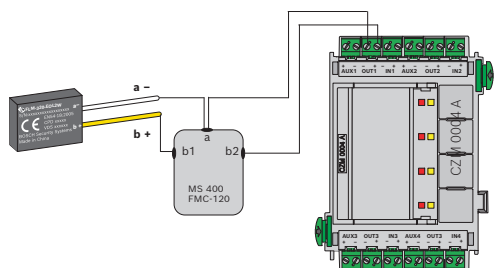
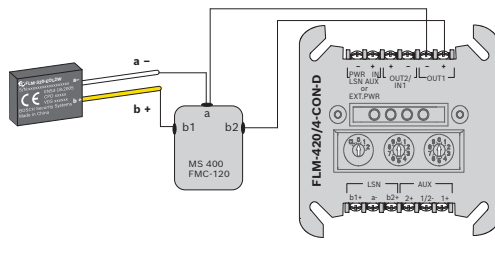

3 |

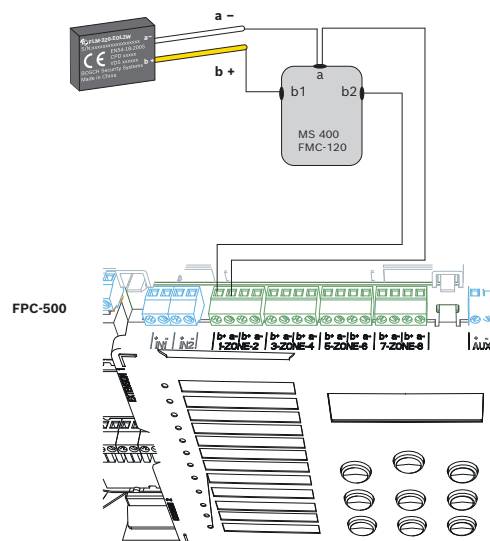

4 |

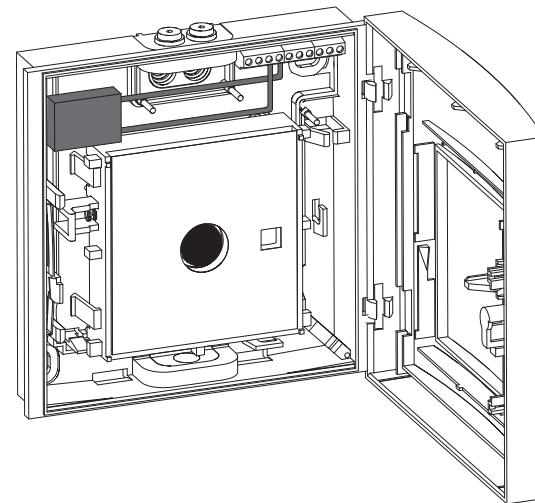

5 |

Functional description / Funktionsbeschreibung

9 ... 15 V DC

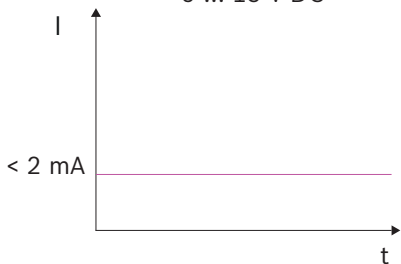

15 ... 30 V DC

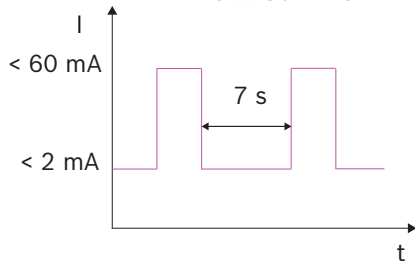

6 |

en:

The end-of-line module enables the termination of conventional lines for creeping open monitoring.

de:

Das EOL-Modul ermöglicht die Überwachung von Gleichstromlinien auf schleichende Unterbrechungen.

fr:

Le module de fin de ligne permet la supervision des lignes conventionnelles pour détecter la présence de circuits ouverts.

it:

Il modulo EOL permette la terminazione delle linee convenzionali per il monitoraggio delle interruzioni di circuito lente.

nl:

Met de EOL-module is het mogelijk de conventionele lijn op onderbrekingen te bewaken.

7 |

Technical data / Technische Daten

U	9 - 30 V DC
I	< 2.0 mA
	-25 ... +70 °C
	< 96 %
	25 x 17 x 8 mm
IEC 60529	IP 30

8 |

FLM-320-EOL2W

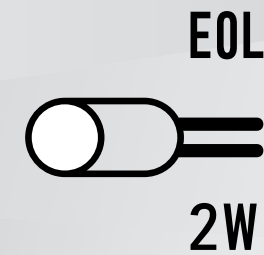

en Installation Guide