

FPP 5000 External power supply kit

www.boschsecurity.com

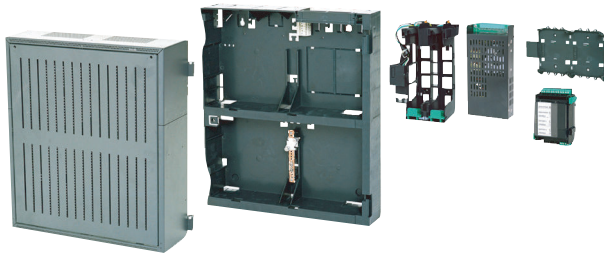

BOSCH
Invented for life



- ▶ Charging process controlled by temperature and time
- ▶ Voltage outputs each electronically fused
- ▶ Can hold two batteries

The FPP-5000 External Power Supply Unit Kit is designed for universal power supply, and has space for two 12 V/45 Ah batteries. This is configured using components of the Modular Fire Panel FPA-5000.

System overview

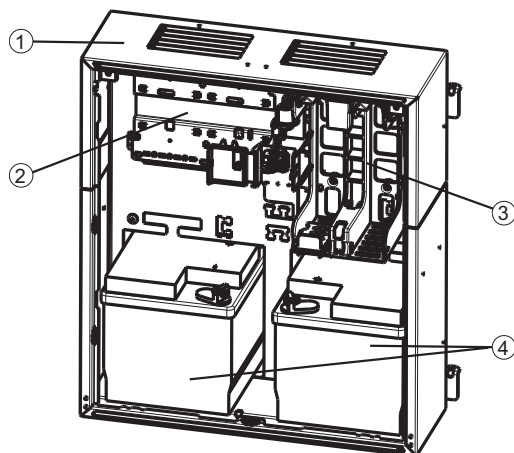

Pos.	Description
1	Power Supply Housing, Frame Installation, medium PMF 0002 A

- 2 Mount for 1 Panel Rail Short PRS 0002 A to hold 1 Battery Controller Module BCM-0000-B
 - 3 Power Supply Bracket for 1 UPS 2416 A Universal Power Supply 24 V/6 A
 - 4 Space for 2 batteries 12 V/45 Ah
- The Power Supply Housing is positioned on a Mounting Frame Medium FMH 0000 A (not shown).

Functions

In the case of the FPP-5000 Power Supply Unit, the Panel Rail made of glass fiber reinforced plastic is fitted a BCM-0000-B Battery Controller Module. The Power Supply Unit is inserted into the Power Supply Bracket, and is immediately operational via the pre-wired plug-and-socket connections. The bracket is equipped with a thermal sensor. The Universal Power Supply UPS 2416 A is protected against excess voltage and reversed polarity. The output voltage is monitored and controlled externally. The output FAULT signals that a malfunction has occurred. The green onboard LED shows that the unit is operational. The BCM-0000-B Battery Controller Module monitors the power supply and controls the charging of the batteries (2 x 12 V / 45 Ah), subject to temperature parameters and set times.

Each voltage output is electronically fused.

Certifications and approvals

Complies with:

- EN 54-4:1997/A1:2002
- EN 54-17:2005

Region	Regulatory compliance/quality marks	
Germany	VdS	G 205050 FPP-5000
Europe	CE	FPP-5000
	CPD	0786-CPR-20357 FPP-5000

Installation/configuration notes

Installation dimensions

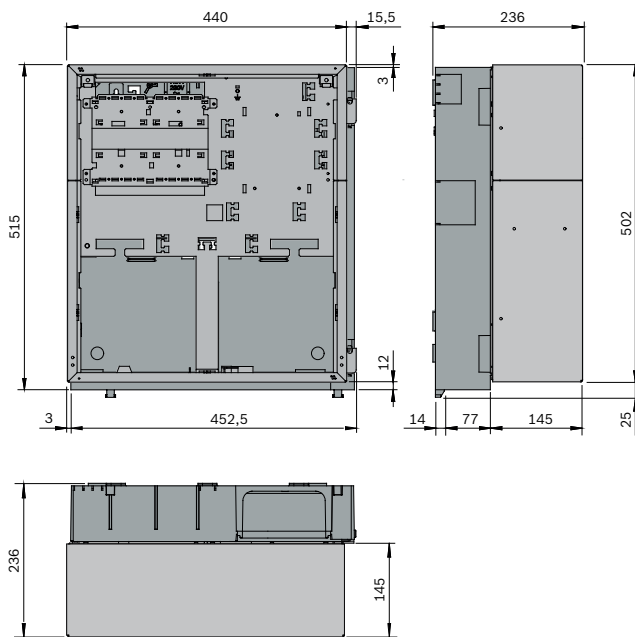

Parts included

Quantity	Component
1	PMF 0002 A Power Supply Housing Frame Installation medium, with Power Supply Bracket
1	FMH 0000 A Mounting Frame Medium
1	UPS 2416 A Universal Power Supply 24 V/6 A
1	PRS 0002 A Panel Rail Short
1	BCM-0000-B Battery Controller Module
1	CPB 0000 A Cable Set BCM/UPS
1	CBB 0000 A Cable Set BCM/Battery
1	Battery pole connection cable for Frame Installation Housing
1	Supplementary package



Notice

Optional: Earth Bar FPO-5000-EB

Technical specifications

Electrical

Input voltage range	100 V AC to 240 V AC
Input frequency range	50 Hz to 60 Hz
Efficiency	85%
Bridging time	> 100 ms at 230 V AC
Output voltage	
• Mains supply	26 to 29 V DC (dependent on temp.)
• Mains supply nominal	26.8 V DC (at 40 °C)
• Battery supply	21 to 23 V DC
Max. output current	6 A
Max. output	160 W (permanent)
Capacity of the fault outputs BAT FAULT, AC FAULT, and collective fault	0 V / 0 to 20 mA
Voltage outputs	
• 2 switch outputs	+24 V / 2.8 A (20.4-30 V), battery buffered

Mechanics

Housing material	Sheet steel, painted
Housing color	Slate gray, RAL 7015 Front: anthracite gray, RAL 7016
Dimensions (installed)	Approx. 527 x 456 x 236 mm

Environmental Considerations

Classes of equipment as per EN 60950	Class I equipment
Permissible operating temperature	-5 °C to 50 °C
Permissible storage temperature	-20 °C to 60 °C
Relative humidity	Max. 95% non-condensing
Degree of protection (IEC 60529)	IP 30
Cooling	Ventilation without ventilator

Ordering information

FPP 5000 External power supply kit
for universal power supply
Order number **FPP 5000**

Accessories

FPP-5000-TI13 Communication interface
Use with External Power Supply Unit Kit as
communication interface between kit and panel
(FPA-5000/FPA-1200 EN54-13).
Order number **FPP-5000-TI13**

FPP-5000-TI Trouble interface

Use with FPP-5000 External Power Supply Unit
Kit 24 V/6 A.
Order number **FPP-5000-TI**

Represented by:

Europe, Middle East, Africa:
Bosch Security Systems B.V.
P.O. Box 80002
5600 JB Eindhoven, The Netherlands
Phone: + 31 40 2577 284
emea.securitysystems@bosch.com
emea.boschsecurity.com

Germany:
Bosch Sicherheitssysteme GmbH
Robert-Bosch-Ring 5
85630 Grasbrunn
Germany
www.boschsecurity.com

North America:
Bosch Security Systems, Inc.
130 Perinton Parkway
Fairport, New York, 14450, USA
Phone: +1 800 289 0096
Fax: +1 585 223 9180
onlinehelp@us.bosch.com
www.boschsecurity.us

Asia-Pacific:
Robert Bosch (SEA) Pte Ltd, Security Systems
11 Bishan Street 21
Singapore 573943
Phone: +65 6571 2808
Fax: +65 6571 2699
apr.securitysystems@bosch.com
www.boschsecurity.asia