

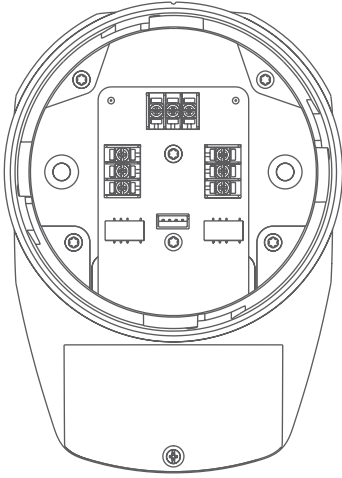

User Guide

In the Box



① Fireray One Base

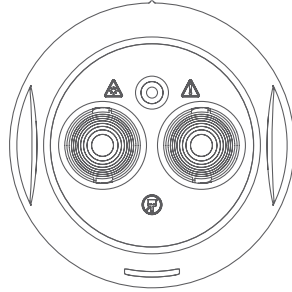

② Fireray One Detector Head

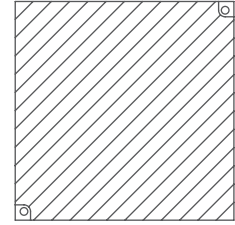

③ Reflector

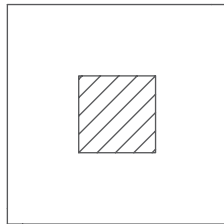

Short Range Mask



User guide

General Information

Installation

All installations should comply with local regulations

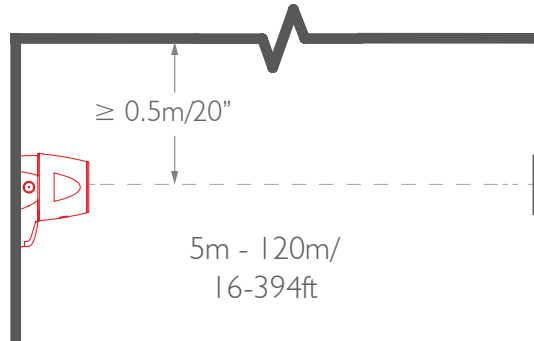
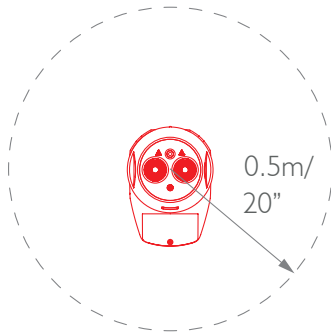

5 - 20m/16-66ft =
1 Reflector + Short Range Mask



20m - 50m/66-164ft = 1 Reflector

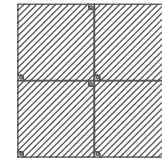

50 - 120m/164-394ft = 4 Reflectors

Do NOT position Detector where personnel or objects can enter the beam path

Do NOT install the Detector or Reflector in environments where condensation or icing are likely to occur unless preventative measures have been taken

Position beam as high as possible, but with a minimum distance of $0.5\text{m}/20''$ from Detector and Reflector to ceiling.

For detectors approved to UL268 refer to NFPA72 for installation guidance. In such installations, it is advised that the maximum distance of Detector and Reflector from the ceiling must be 10% of the distance between floor and ceiling

Ensure correct Reflector selected for the appropriate distance

Mount Detector and Reflector directly opposite each other

Do not mount Reflector onto reflective surfaces

Wiring

The Fireray One contains software that processes the output of the detector and generates a Fire and Fault status. This status is output using volt-free relays so that it can be interfaced to all types of conventional Fire Control Panel (FCP). To wire a single Detector to an FCP, use the following wiring diagram.

Components not supplied:

1. Fire Resistor (**Note 1**) - value is specified by the FCP manufacturer.
For U.S. installations it is typically a short circuit.
2. End Of Line ('EOL') component - supplied by FCP manufacturer

After installation, check operation of Fire and Fault connections to the FCP - see page 15.

Apply a voltage of 5V to 40V to 'Ext Reset' contact for at least 2 seconds to clear a latched fire condition – see page 14 for latching mode setting.

CAUTION: For system monitoring – Do not use looped wire under any terminals.
Breakwire run to provide monitoring of connections.

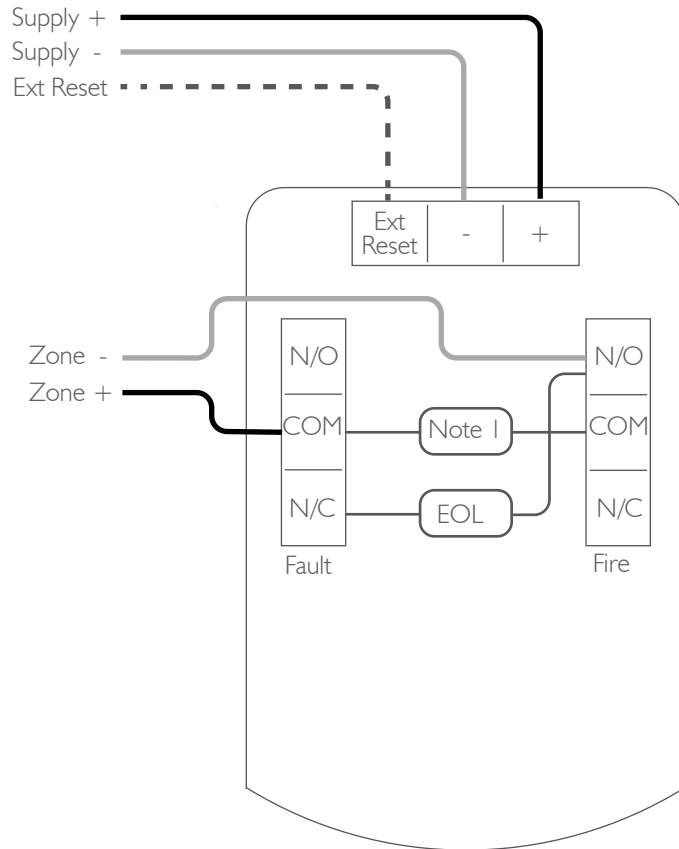

When using more than one Detector on a single zone of a conventional FCP, it is important to choose the correct method of wiring. Incorrect wiring may result in a Detector isolating subsequent devices on that zone if it enters a Fault condition, and may prevent these subsequent devices signalling a Fire condition back to the FCP.

If the FCP monitors for point detector removal, it is possible to use the following wiring diagram which uses a diode to provide zone continuity in the event of a Fault state on any Detector.

Recommended diode type: Schottky, 60 Volt, 1 Amp, must be UL listed for installations meeting NFPA72

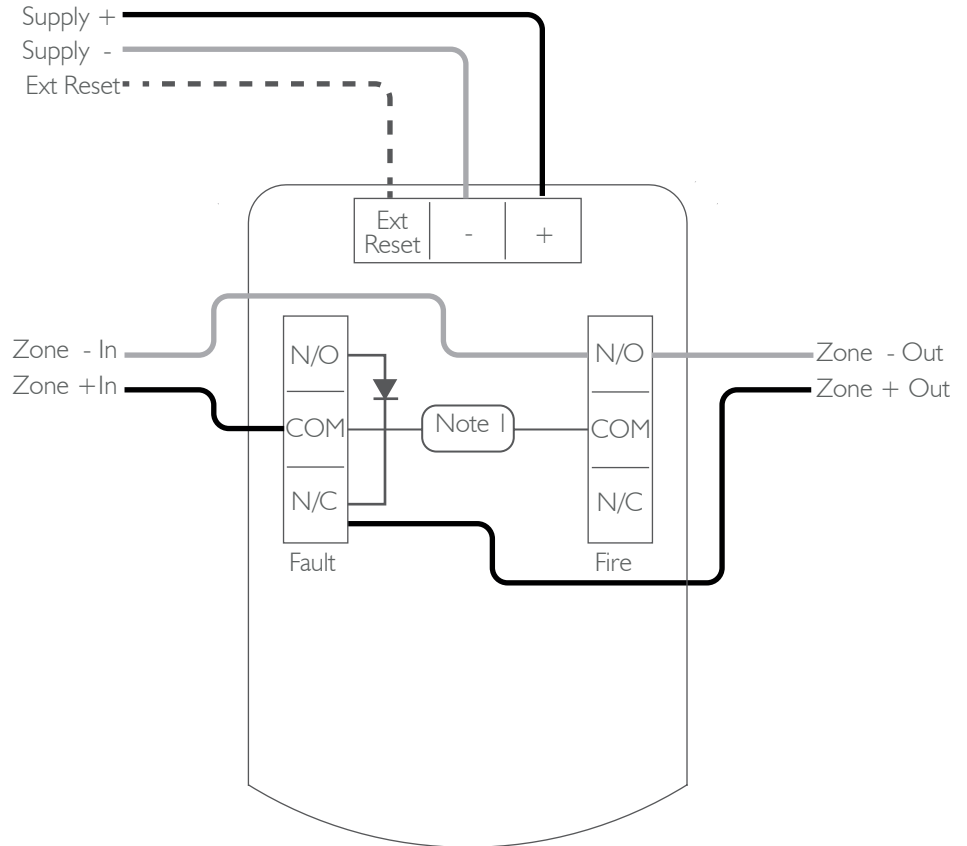

Mounting

Mount Base

Mark and drill holes for mounting of Base. Using appropriate hardware (not supplied) mount base securely in orientation shown.

Plug the cable from the Detector head into the connector on the PCB in the Base.

Locate the Detector Head on the base. Grip sides of Detector Head and rotate clockwise to lock together.

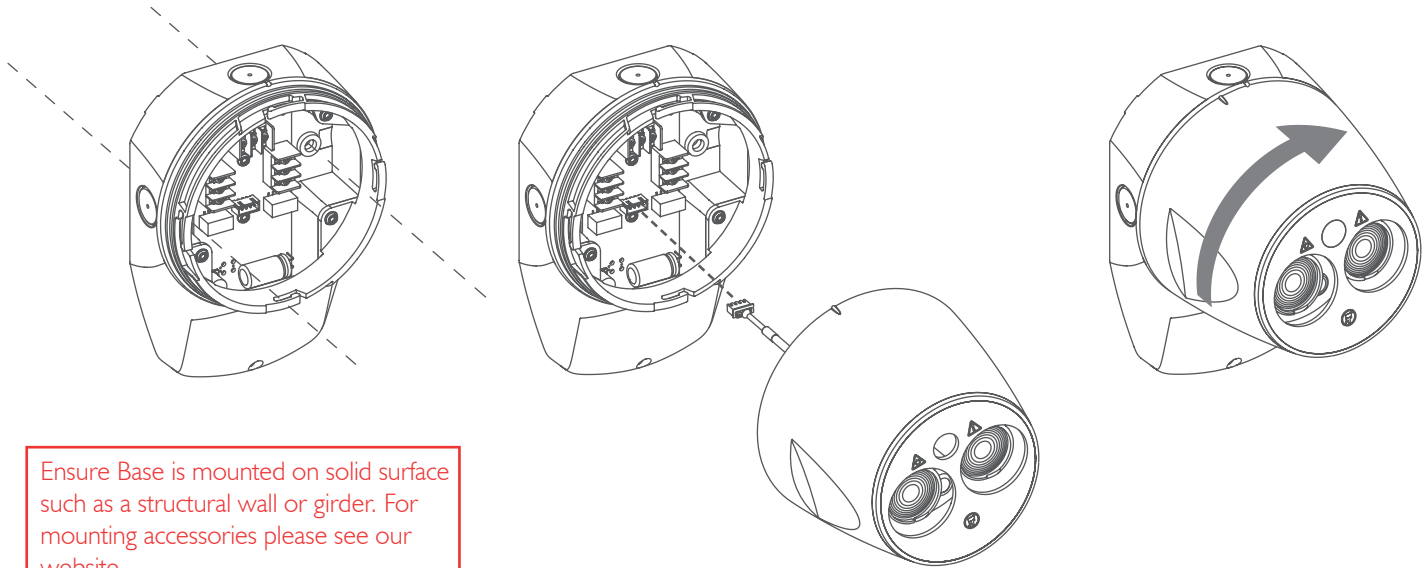

Ensure Base is mounted on solid surface such as a structural wall or girder. For mounting accessories please see our website

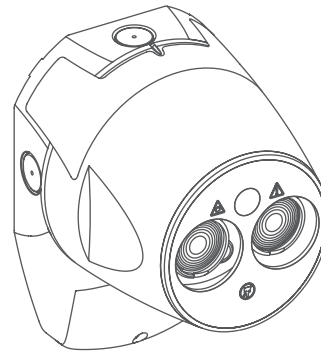
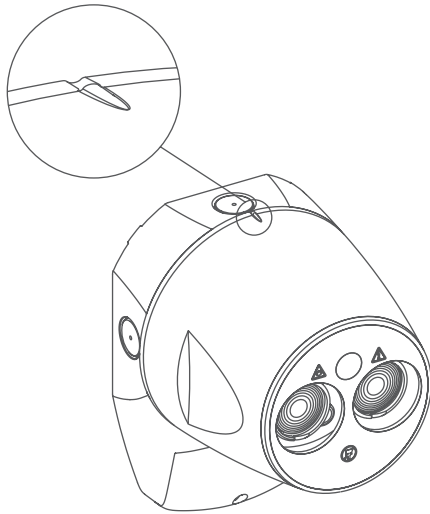

Ensure the 'Pip and Dip'
details align

Alignment

Access User Interface

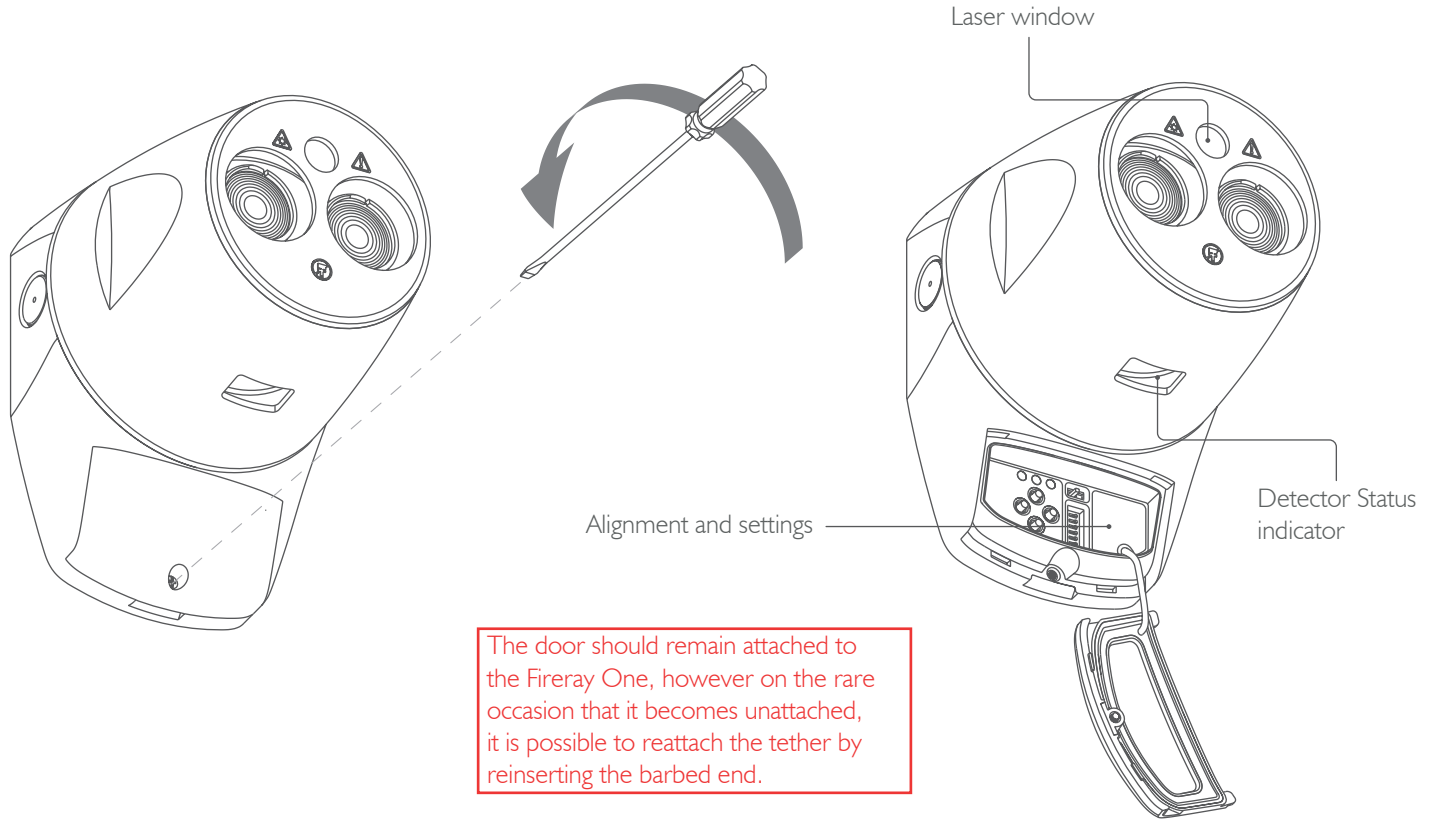

Alignment Status indicators

Slide Switch

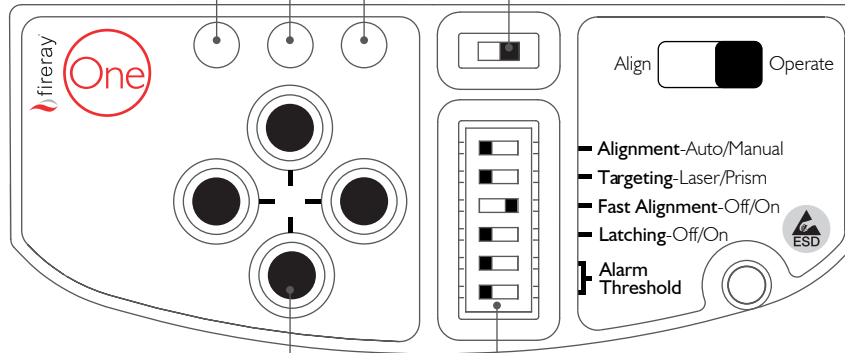

Direction keys

Settings Switch

Alignment

Fireray One will align in less than a minute if Fast Alignment is selected. In this mode, the current consumption during alignment will be 33mA (it will revert to 5mA when alignment is completed).

To select fast alignment mode, ensure the fast alignment setting switch is set to the right hand position

If lower consumption during alignment is required, then ensure the Fast Alignment setting switch is set to Off – consumption will remain at 5mA but alignment can take up to 15 minutes.



LASER RADIATION - AVOID
DIRECT EYE EXPOSURE
POWER OUTPUT < 5mW-
CLASS IIIa LASER
Wavelength 630 - 680 nm

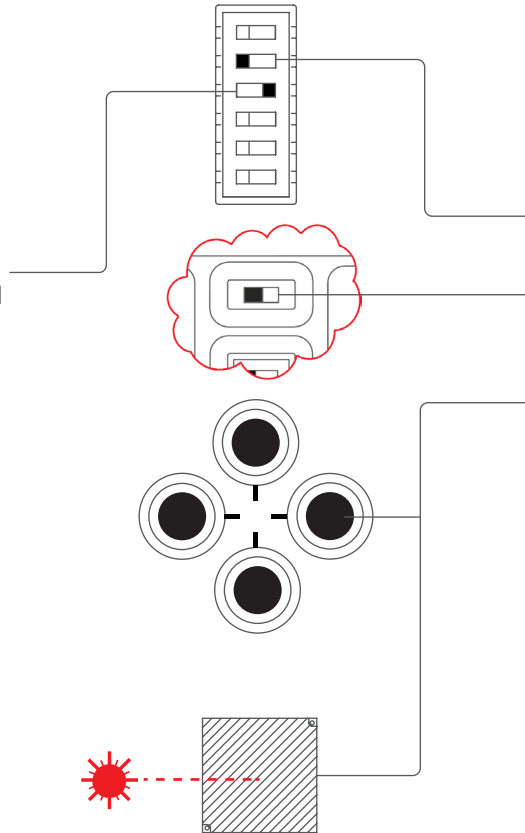

Stage I (Targeting) is the process of using the laser to get the infra-red beam close enough to the reflector so that Alignment can begin.

Ensure the targeting setting switch is set to the left hand position.

To turn the laser on move the slide switch to the left hand position.

Use the direction keys to move the laser point on to the Reflector.

If the laser cannot be seen, for example in very bright environments or over long distances, then Prism Targeting mode can be used – refer to the page 12.

Once Targeting is complete, move to Stage 2.

Stage 2 (Alignment) moves the infra-red beam exactly to the middle of the Reflector.

To select automatic alignment, ensure the alignment setting switch is set to the left hand position.

To begin automatic alignment move the slide switch to the right hand position.

The alignment status LEDs will flash to show progress:

- The right-hand green LED will flash continually throughout alignment to indicate alignment is occurring
- The left-hand green LED flashes to indicate which stage (1 to 4) the process is at.
- If for any reason the alignment fails the amber LED will flash, and the number of times it flashes indicates which alignment stage failed.

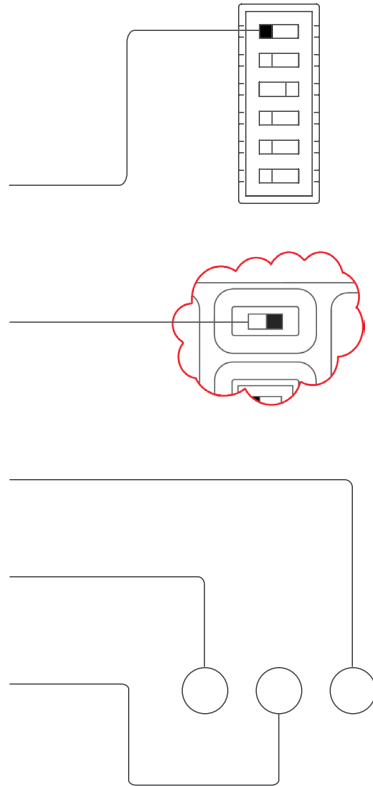

If alignment fails, ensure that the correct number of reflectors are installed, that the correct clearance has been given, and that there are no reflective surfaces around the reflector or close to the beam path, and try the alignment again.

If alignment repeatedly fails, it is possible to do a manual alignment.

Once the alignment is successfully complete, the right-hand green LED will flash for 10 seconds.

The Fire and Fault relays will go to normal state, and the Detector will flash its status indicator green every 10 seconds.

You are now ready to select Alarm Thresholds and Latching mode, and to test the Detector to ensure it is operating and connected to the Fire Control Panel correctly.

Alignment

Prism targeting

Prism targeting should only be used when the laser cannot be seen, for instance in high ambient lighting conditions or over very long distances.

Ensure targeting setting switch is in the right hand position.

Move the slide switch to the left position. The green and amber LEDs will flash together for a few seconds to show the detector has started Prism targeting.

If the green LED stays illuminated the Detector is receiving enough light back from the Reflector. Cover the reflector – if the green LED goes off then the light being received by the Detector is coming from the Reflector and you can now proceed to the Alignment stage. If the green LED stays illuminated with the reflector covered then the light received by the detector is being reflected by some other object in or around the beam path. Take care to make sure there are no reflective objects within 0.5m of the centre of the beam path, and try Prism Targeting again.

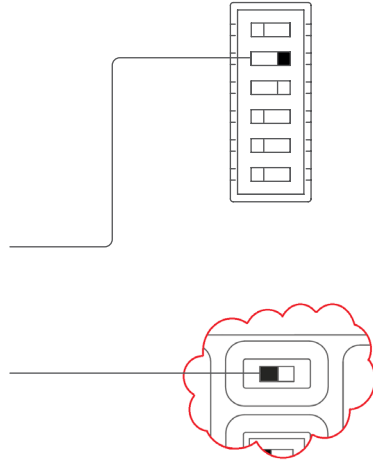

The amber LED will flash every two seconds if the Detector is not receiving enough light from the Reflector. The number of flashes indicate how strong a signal it is receiving. Using the direction buttons, move the detector in one axis until the amber flashes increase. If the number of flashes stays the same, then keep going in the same direction. If the number decreases then reverse direction. Once the number of flashes starts to increase then keep going until either:

- The green LED comes on, at which point cover the reflector as described above
- The amber flashes start to decrease again, at which point reverse direction for 2 steps and perform the same process in the other axis

If Prism Targeting has been performed on both axes and the green LED is still not on then ensure that the correct number of reflectors for the range has been used, that the distance has not exceeded the maximum (120m/394ft) and that the reflector and detector are parallel to each other.

Manual Alignment

Manual alignment should only be used when Automatic alignment has failed even after it has been verified that the correct number of reflectors have been installed and the correct clearance around the beam path has been given.

Perform targeting as previously described

Ensure Setting Switch 1 is in the right-hand position, and move the Slide Switch to the right-hand position

The green and amber LEDs may flash if the detector needs to perform an initial power adjustment

Once the LEDs have stopped flashing, use the direction buttons to move the detector in the up-down axis. First, use the direction button in the down direction. Press the button once, and wait to see what the LED indication shows. If both amber and green LEDs flash, the signal has not changed so no further movement in that axis is needed.

If the amber LED flashes, the signal is smaller and the detector is moved away from the reflector. The next movement must be in the opposite direction. Using the direction buttons, move the detector again – this time there should be a green flash.

If the green LED flashes, the signal is larger and the detector is moving closer to the reflector. The next movement must be in the same direction. Keep moving the detector, waiting for the LED flash each time. If the green LED keeps flashing, keep going in the same direction. If the amber and the green LED flashes, then move onto the other axis. If the amber LED flashes, move back in the opposite direction once, then move onto the other axis.

Follow the same process with the direction buttons, this time in the left-right axis. Start by moving the left direction, and follow the same LED flashes as described in the up-down axis.

Once the alignment has been completed on both axis then move Setting Switch 1 to the left-hand position. The right-hand green LED will flash for 10s, the Fire and Fault relays will go to normal state, and the Detector will flash its status indicator green every 10 seconds.

You are now ready to select Alarm Thresholds and Latching mode, and to test the Detector to ensure it is operating and connected to the Fire Control Panel correctly.

Settings

Fire Threshold

Threshold	SW5	SW6
25%	On	On
35%	Off	Off
55%	On	Off
85%	Off	On

EN54-12 Threshold Selection: Only the 25% and 35% thresholds are approved. Both are suitable for separations of 5m to 120m.

UL268 Threshold Selection: Select the correct threshold for the installed distance:

Separation between Detector and Reflector	Acceptable Alarm Thresholds
<25ft (<7.5m)	25%
25 – 55ft (7.5 – 16.5m)	25%, 35%
55 – 110ft (16.5 – 33.5m)	35%, 55%
110 – 175ft (33.5 – 53m)	55%, 85%
175 – 394ft (53 – 120m)	85%

UL Sensitivity Acceptance Test

Successful alignment of the Detector will check correct operation of the Detector and its sensitivity level.

Latching Mode

If Latching Mode is selected, the detector will remain in Fire Alarm condition even after the signal has recovered to its normal level. To select Latching Mode move the Latching Mode switch to the On position.

External Reset

External Reset can be used to clear a latched fire alarm condition, which will be cleared when the voltage on the External Reset connection goes high or low, i.e. from 0V to a voltage greater than 5V, or from a voltage greater than 5V to 0V.

Alternatively, remove power from the detector for at least 10 seconds.

Status Indications and Troubleshooting

Status Indications

During normal operation the Detector Status indicator LED will flash green every 10 seconds, and both Fire and Fault relays will be in their normal position.

If the detector is in Fault state, its LED will flash amber every 10 seconds to indicate Signal High/Low Fault, every 5 seconds to indicate AGC/Compensation Fault, and every 3 seconds to indicate Internal Fault. The Fault will change state.

If the detector is in Fire state, its LED will flash red every 5 seconds and the Fire relay will change state.

Cleaning

The Detector will automatically compensate for dust build up by changing its AGC level. Once the AGC limit has been reached, the Detector will indicate a Fault and cleaning must be performed.

It is therefore recommended that the Detector lens windows and the Reflector are periodically cleaned with a soft lint-free cloth to prevent AGC limit faults occurring.

After cleaning, if the Detector is in Fault state, the signal strength may have increased above the Signal Too High threshold. If this is the case, re-align the Detector.

Testing

After installation or cleaning it is recommended that a Fire test is performed.

Fire Test: Cover the reflector slowly so that it takes longer than 5 seconds to cover. The Detector will indicate Fire after 10 seconds.

In order to test the obstruction fault detection, the reflector should be covered quickly (clear to covered in under two seconds). The detector should go into Fault after a 10 second delay. If the detector goes into Fire then it is likely that there are stray reflections entering the detector and preventing the signal from dropping to the fault threshold. This can be overcome by returning to the detector and pressing the left and right buttons simultaneously. This will tell the detector that the previously recorded Fire should have been a Fault, allowing the detector to compensate for the stray reflections. The detector will flash the green alignment status indicator LED three times to show that the Set Compensation feature has been activated. This feature can only be used once after the detector is aligned.

Repeating the obscuration test should then result in a Fault being indicated.

Alternatively, use the Alarm Filter from the Fireray Commissioning Kit which will test 25% 35% and 55% alarm thresholds.

Technical Information

Fireray One Parameters	Minimum	Typical	Maximum	Unit
Operating Voltage	14	-	36	V
Operating Current	4.5	5.0	5.5	mA
Operating Current – Alignment Modes	31	33	35	mA
Response Thresholds (25%, 35%, 55%, 85%) (note – only 25% and 35% are EN54-12 approved)	1.25 25	1.87 35	8.24 85	dB %
Delay to Alarm	-	10	-	s
Delay to Fault	-	10	-	s
Operating Distance (Separation between Detector and Reflector) (4 reflectors required for >50m, >164ft)	5 16	-	120 394	m feet
Rapid Obscuration Fault Threshold	-	85	-	%
Maximum angular alignment range of detector	-	-	±4.5	Deg
Tolerance to beam misalignment (per EN54-12) – Detector	-	±0.5	-	Deg
Tolerance to beam misalignment (per EN54-12) – Reflector	-	±5	-	Deg
Optical Wavelength	-	850	-	nm
Operating Temperature	-20 -4	-	+55 +131	°C °F
Storage Temperature	-40 -40	-	+85 +185	°C °F
Relative Humidity (non-condensing)	-	-	93	%RH
IP rating	-	55	-	-
Fire & Fault Relays (VFCO, Resistive) - Contact voltage	-	-	30	V DC
Fire & Fault Relays (VFCO, Resistive) - Contact current	-	-	2	A
Cable gauge	22 0.5	- -	14 1.6	AWG mm
Housing flammability rating	-	UL940 V0	-	-

Fireray One Dimensions and Weights	Width (mm)	Height (mm)	Depth (mm)	Weight (kg)
Reflective Detector, including detector base	134	182	151	0.7
Reflector	100	100	10	0.1

Equipment Disposal



Products marked with this symbol cannot be disposed of as unsorted municipal waste in the European Union. For proper recycling, return this product to your local supplier upon the purchase of equivalent new equipment, or dispose of it at designated collection points. For more information see: www.recyclethis.info.