

ICP-MAP5000-K/2 MAP5000 kit

Modular Alarm Platform 5000



This kit includes all relevant key components to build up a MAP5000 system with its basic structure.

It includes:

- 1 x MAP5000 panel
- 1 x MAP Touch keypad 5000
- 1 x MAP LSN Gateway
- 1 x MAP Interface module, DE
- 1 x MAP Power supply, 150W
- 1 x MAP Panel enclosure

Via the BDB (Bosch Data Bus) based on CAN (Controller Area Network) technology and modular approach, the system can be expanded and scaled by internal and external devices according to the individual requirements of each application.



- ▶ Supports up to 32 multilingual keypads with touchscreen
- ▶ Supports up to 8 LSN Gateway modules with up to 127 devices each
- ▶ Supports additional power supplies
- ▶ Communication with the monitoring station via an external communicator

System overview

MAP5000 panel

Terminals and connectors - front view

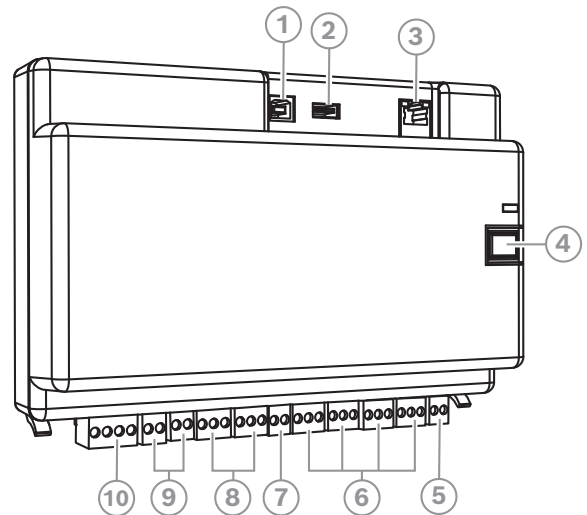

Element	Description
1	USB host port - currently not enabled
2	USB port - currently not enabled
3	Ethernet port
4	Installer button
5	Tamper switch input

Element	Description
6	Eight supervised inputs
7	Auxiliary power output
8	Two form C dry-contact relay outputs
9	Two auxiliary switched voltage outputs
10	External Bosch Data Bus (BDB) port

Terminals and connectors - back view

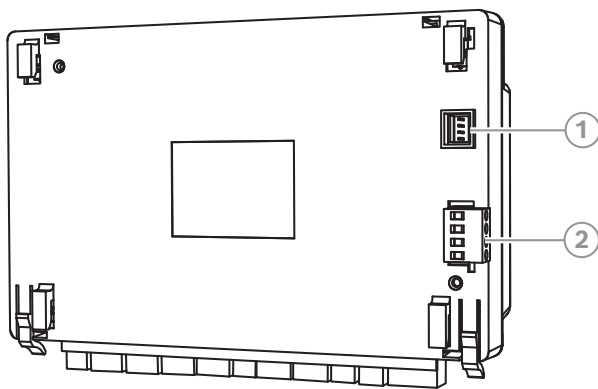

Element	Description
1	Power supply input connector
2	Internal Bosch Data Bus (BDB) port

Functions

MAP5000 panel

The MAP panel supports up to 1500 addresses, 500 areas, and 996 users. As part of a Modular Alarm Platform 5000 solution, the MAP panel connects to building management systems through internet protocol (IP).

Bosch Data Bus (BDB) based on CAN technology

The MAP panel provides two data buses:

- **Internal BDB** - Limited to 3 m in total length, the internal BDB connects the MAP panel to other MAP devices.
- **External BDB** -Up to 1000 m in total length, the external BDB allows keypads, LSN Gateways, CAN Splitter Modules and power supplies to be placed at the point of use, promoting greater efficiency.

ICP-MAP5000-2 | F.01U.245.556

Firmware upgrades

The firmware of all devices in the MAP system can be upgraded or updated with Remote Programming Software for MAP (RPS for MAP). This allows for on-site or off-site (IP through Ethernet) upgrades or updates.

Communication with Software Packages

The MAP system allows separate communication with the following:

- **Management systems**

The system can be integrated into different management systems over the REST based API - Open Intrusion Interface (OII).

- **Remote Programming Software for MAP (RPS for MAP)**

Programming and diagnostic software for MAP products that provides remote programming, record storage, remote control, and diagnostics options. Use of RPS for MAP is necessary to configure MAP5000 Panels, MAP5000 Keypads, and MAP peripherals.

MAP Touch keypad 5000

This easy to use keypad gives users access to system functions through an engaging interface with intuitive icons. Users directly touch the icons on the screen to arm, disarm, or select other menu options. Text is shown in language based on the user's login.

IUI-MAP0001-3 | F.01U.396.542

MAP LSN Gateway

Each LSN gateway module connects one Local Security Network (LSN) loop or up to two stubs at a maximum output current of 300 mA. Each module supports up to 127 LSN devices.

IUI-MAP0010 | F.01U.064.521

MAP Interface module, DE

The MAP interface module DE is the primary communication interface between the MAP panel and the communicator.

ICP-MAP0007-2 | F.01U.245.559

MAP Power supply, 150W

This power supply and battery charger unit converts 230 VAC input into 24 VDC nominal and 28 VDC fixed outputs.

IPP-MAP0005-2 | F.01U.245.558

MAP Panel enclosure

The MAP panel enclosure kit contains one hinged mounting plate to hold the modules, one tamper switch, an enclosure lockset, and one 230 V terminal block.

ICP-MAP0111 | F.01U.300.119

More information

For more information about functions of individual MAP product, go to [your local online Product Catalog](#) and the corresponding product page.

Regulatory information

Battery information:

For NFA2P certification, this panel was tested with the FIAMM FG24204 battery.

OSS information:

MAP5000 Panels, MAP5000 Keypads, and RPS for MAP contain OSS components. For information on software packages, please refer to: [OSS used in Bosch products](#).

Region	Regulatory compliance/quality marks	
Europe	CE	
	EN50131	G111040 Grade 3
Germany	VdS	G111040 VdS 2252, Class C
	VdS-S	S 112016

Parts included

Quantity	Component
1	MAP5000 panel
1	MAP Touch keypad 5000
1	MAP LSN Gateway
1	MAP Interface module, DE
1	MAP Power supply, 150W
1	MAP Panel enclosure
1	Installation Guide

Technical specifications

MAP5000 panel

Electrical

Operating voltage (VDC)	19 VDC – 29 VDC
Nominal voltage (VDC)	28 VDC
Current consumption (mA)	250 mA – 500 mA

On-board inputs

Maximum line resistance (Ω)	100 Ω
--------------------------------------	--------------

Outputs

Maximum current consumption (mA) per output	1000 mA
---	---------

Relay outputs

Maximum operating voltage (VDC)	30 VDC
Maximum operating voltage (VAC)	30 VAC
Back-up time	Determined by battery capacity and system load. Consider time or capacity limits for recharging the batteries regarding local regulations (such as VdS) or EN standards if needed.

Mechanical

Dimensions (H x W x D) (mm)	146 mm x 216 mm x 55 mm
Weight (g)	450 g
LED indication	Green for operating status

Number of output modules

Auxiliary output	1
Power output	2
Form C dry-contact relay output	2

Number of devices

LSN Gateway module	8
Touch keypad	32

Environmental

Operating temperature ($^{\circ}\text{C}$)	-10 $^{\circ}\text{C}$ – 55 $^{\circ}\text{C}$
Storage temperature ($^{\circ}\text{C}$)	-20 $^{\circ}\text{C}$ – 60 $^{\circ}\text{C}$
Operating relative humidity, non-condensing (%)	5% – 95%
IP rating	IP30
Impact protection	IK04
Usage	Indoor
Environmental class (EN 50130-5)	II
Environmental class (VdS 2110)	II

Ordering information

ICP-MAP5000-K/2 MAP5000 kit

Kit including one MAP5000 panel, one MAP touch keypad, one MAP LSN gateway module, one MAP interface module, one MAP power supply and one MAP panel enclosure Kit.

Order number **ICP-MAP5000-K/2 | F.01U.415.887**

Represented by:

Europe, Middle East, Africa:

Bosch Security Systems B.V.
P.O. Box 80002
5600 JB Eindhoven, The Netherlands
www.boschsecurity.com/xc/en/contact/
www.boschsecurity.com

Germany:

Bosch Sicherheitssysteme GmbH
Robert-Bosch-Platz 1
D-70839 Gerlingen
www.boschsecurity.com

North America:

Bosch Security Systems, LLC
130 Perinton Parkway
Fairport, New York, 14450, USA
www.boschsecurity.com

Asia-Pacific:

Robert Bosch (SEA) Pte Ltd, Security Systems
11 Bishan Street 21
Singapore 573943
www.boschsecurity.com/xc/en/contact/
www.boschsecurity.com