

ISP-SM90-120 LSN Seismic detector



LSN

- ▶ Completely protected against electrical influences
- ▶ Programmable sensitivity and response time via LSN
- ▶ Remote controlled reduction of sensitivity
- ▶ Alarm, tampering and faults are evaluated via the LSN bus
- ▶ Compatibility mode for GM570 LSN available

The seismic detector is used for monitoring armored cabinets, cash boxes, automatic teller machines, strong rooms, night safes, modular vaults, and vault walls for all known burglary tools such as diamond-tipped drills, hydraulic rams, oxygen lances and explosives.

Functions

The seismic detector has a double housing to provide protection against electromagnetic influences and deliberate or accidental damage. Mechanical vibrations caused by a burglary attempt are detected and analyzed by the seismic detector sensor, and an alarm is triggered.

Temporary reduction in sensitivity

To prevent false alarms caused by loud operational noises, e.g. use of the object intake mechanism on day/night vaults, the remote sensitivity of the detector can be temporarily reduced to approx. 1/8 of the pre-set value via a control input (e.g. contact switch on the object intake mechanism).

Notice

When reducing sensitivity, compliance with the relevant VdS regulations within the context of the system must be checked and accepted by VdS.

ISN-GMX-S1 test transmitter (optional)

The optional ISN-GMX-S1 test transmitter is a component of the test system for the seismic detector. Installing the test transmitter allows the

seismic conductivity of the mechanical mountings to be checked along with the functionality of the electronics.

Regulatory information

Region	Regulatory compliance/quality marks	
Europe	CE	[ISP-SM90-120]
Russia	GOST	TC N RU Д-НЛ.МН09.В.00334 EAC
Germany	VdS	G111100

Installation/configuration notes

Detection zone

The surface of a mechanical obstruction (vault or wall of an armored cabinet) that is being monitored by a seismic detector is referred as the detection zone. The detection zone is not affected by ultrasound detectors in the same room.

The detection zone is highly dependent on the material of the object being monitored. Due to practical experience, the effective range for steel is $r = 2$ m and for concrete is $r = 4$ m.

The detection zones for detectors on vault walls can extend along a part of the ceiling or the floor if the rebars are well connected to each other. In such cases the effective range is reduced to 3/4 of the set zone.

Joints create attenuation between two materials for impact sound transmission.

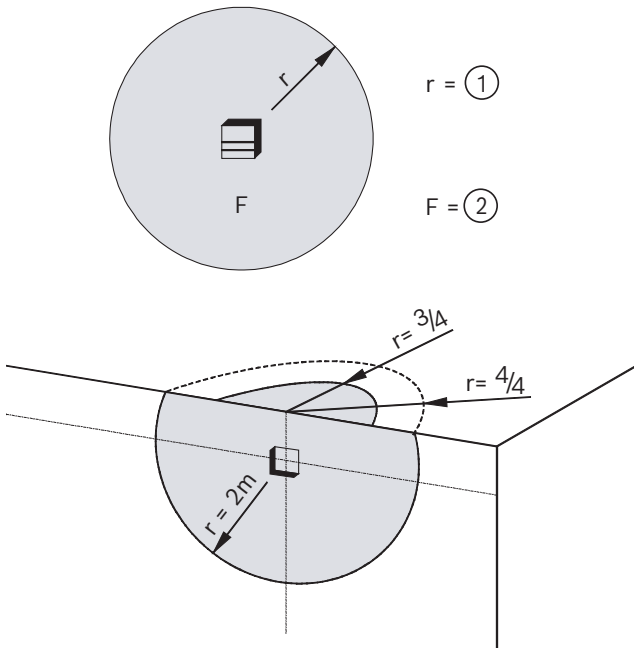

- 1 Effective range
- 2 Detection zone

(i) Notice

To ensure functionality, fit each folding door and the body of a vault with at least one seismic detector.

(i) Notice

If the vault dimensions exceed the detection zone of one seismic detector or if the detection zone is reduced due to range reduction at body edges, add additional seismic detectors. When used on modular vaults, take the panel structure into consideration when allocating seismic detectors.

Surface monitoring

To simplify planning for large surfaces, convert the circular detection zone into a square:

- For 75% surface monitoring, convert diameter to 4 m x 4 m square
- For 100% surface monitoring, create a 3 m x 3 m square within circle

Interim values can also be selected. Multiple seismic detectors do not mutually influence each other.

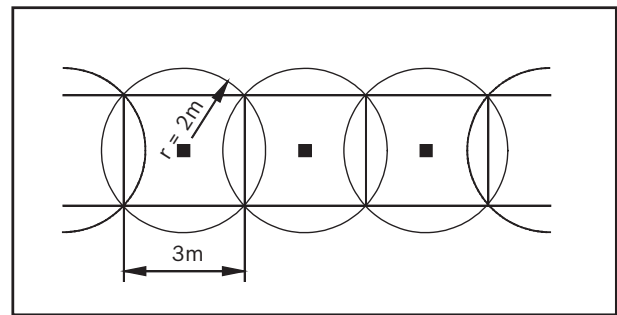
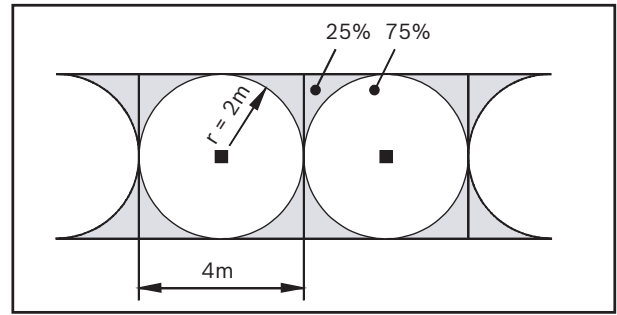

Principles for monitoring modular vaults

These principles apply to modular vaults with the following dimensions:

- Thickness: 100 mm - 400 mm
- Widths: up to 1000 mm
- Lengths: up to 6500 mm

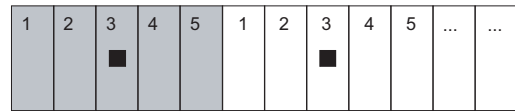

Fig. 1: Vault with detector allocation

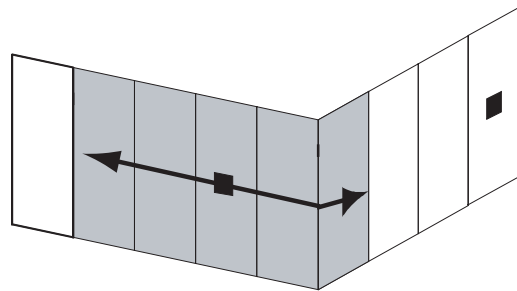

Fig. 2: Weld wall/wall corner connection end to end

When using a seismic detector on steel and concrete modular vaults, the following principles must be observed:

- Use one seismic detector for a maximum of five wall panels, with the detector placed on the central panel.
- Weld all joints between panels to a screw connection every 40 to 50 cm with a weld seam 3 to 4 cm long.

- Weld corner connections for wall panels from end to end if the detection zone is used around the corners.
- For wall panels with assembled detectors set to sensitivity A, the directly adjacent floor and/or ceiling panel can be included in the detection zone, if the relevant impact position is welded end to end.
- With mixed structures that combine various panel thicknesses, weld impact positions from end to end.
- Do not place seismic detectors directly on panels where bearings from cassette transport lifts, ventilators or other mechanical units are fixed.
- For panels with an inlet or outlet opening, use a seismic detector that also monitors the adjacent panels.
- Use one seismic detector on each individual door.
- Use the following settings:

Application	Sensitivity	Response time
Max. 5 elements	A	Standard
Max. 3 elements	B	Standard
On doors	C or D	Delayed

Information on night safes

Dropping cash boxes into night safes results in brief, acute seismic signals. These can be reduced by the following measures:

- Joint between inlet channel and night safe
- Acoustic insulation between inlet channel and night safe
- Coating the opening cover and the inside of the safe with sound-absorbing material
- Using plastic cash boxes

Parts included

Quantity	Component
1	Seismic detector

Technical specifications

Electrical

Maximum operating voltage in VDC	33
Maximum current consumption in mA	2.43
EMC strength 0.01 to 2 GHz (IEC801-3) in V/m	30

Test point: analog integration signal

Standby level in V	0
--------------------	---

Integration start in V	1
Alarm threshold (no load) in V	3

Sensitivity reduction input, terminal 10

Low sensitivity setting in V	<1.5
Sensitivity setting	8 levels of sensitivity are software programmable, depending on control panel

Mechanical

Dimension in cm (H x W x D)	2.3 x 8.9 x 8.9
Weight in g	220
Housing material	Metal
Color	Light gray
Sensitivity adjustability	6 fixed levels + 1 freely programmable object (SW programmable, depending on control panel)
Effective range in m (steel)	R=2
Effective range in m (concrete and iron-reinforced concrete)	R=4 (with default setting)
Detection zone in m ² (steel)	12.5
Detection zone in m ² (concrete and iron-reinforced concrete)	50

ISN-GMX-B0 floor box (optional)

Dimension in cm (H x W x D)	15.0 x 15.0 x 4.9
Dimension in cm (H x W x D) with flange	22.0 x 15.0 x 4.9
Maximum load in kg	1000

Environmental

Minimum operating temperature in °C	-20
Maximum operating temperature in °C	70
Maximum relative humidity in %	95 (DIN class F)
Protection class	IP 43 IP 50 (with an ISN-GMX-B0 floor box)
Security level	IK04

Environmental class	III
---------------------	-----

Ordering information

ISP-SM90-120 LSN Seismic detector

For monitoring vault doors, modular vaults and vault walls

Order number **ISP-SM90-120 | F.01U.173.560**

Accessories

ISN-GMX-P0 LSN seismic detector, mounting plate

Mounting plate for seismic detectors. Suitable for mounting seismic detectors to steel or concrete surfaces.

Order number **ISN-GMX-P0 | F.01U.003.366**

ISN-GMX-B0 LSN seismic detector, floor box

Floor box for mounting a seismic detector.

Order number **ISN-GMX-B0 | F.01U.003.365**

ISN-GMX-S1 Seismic detector, test transmitter

Test transmitter for installation under a seismic detector. Checks the detector and the physical contact between the detector and the protected object.

Order number **ISN-GMX-S1 | F.01U.003.371**

ISN-GMX-W0 Wall-recess kit

Wall recess set for surface or flush mounting a seismic detector to a wall.

Order number **ISN-GMX-W0 | F.01U.003.372**

Represented by:

Europe, Middle East, Africa:
Bosch Security Systems B.V.
P.O. Box 80002
5600 JB Eindhoven, The Netherlands
Phone: +31 40 2577 284
www.boschsecurity.com/xc/en/contact/
www.boschsecurity.com

Germany:
Bosch Sicherheitssysteme GmbH
Robert-Bosch-Ring 5
85630 Grasbrunn
Tel.: +49 (0)89 6290 0
Fax: +49 (0)89 6290 1020
de.securitysystems@bosch.com
www.boschsecurity.com

North America:
Bosch Security Systems, LLC
130 Perinton Parkway
Fairport, New York, 14450, USA
Phone: +1 800 289 0096
Fax: +1 585 223 9180
onlinehelp@us.bosch.com
www.boschsecurity.com

Asia-Pacific:
Robert Bosch (SEA) Pte Ltd, Security Systems
11 Bishan Street 21
Singapore 573943
Phone: +65 6571 2808
Fax: +65 6571 2699
www.boschsecurity.com/xc/en/contact/
www.boschsecurity.com