

## Industrial strobes



The industrial strobes PY X-M-10-SSM color red and white are universally applicable optical and acoustical devices for fire alarm and security technology, 10 J, IP 66, 24 VDC, EN 54-23 compliant.

### Regulatory information

Region	Regulatory compliance/quality marks	
Europe	CPR	0786-CPR-21499 PY X-M-10-SSM
Germany	VdS	G216036 PY X-M-10-SSM
Europe	CE	PY X-M-10-SSM
Poland	CNBOP	4560/2022 PY X-M-10-SSM
Russia	GOST	C-DE.PB68.B.00353

- ▶ Certified according to EN 54-23 O category, type B
- ▶ Economical, largest possible signalling area thanks to effective xenon technology
- ▶ Four different flash frequencies can be selected via DIP switch
- ▶ Light color in red or in white available
- ▶ Strobes can be operated synchronized with each other

### Installation/configuration notes

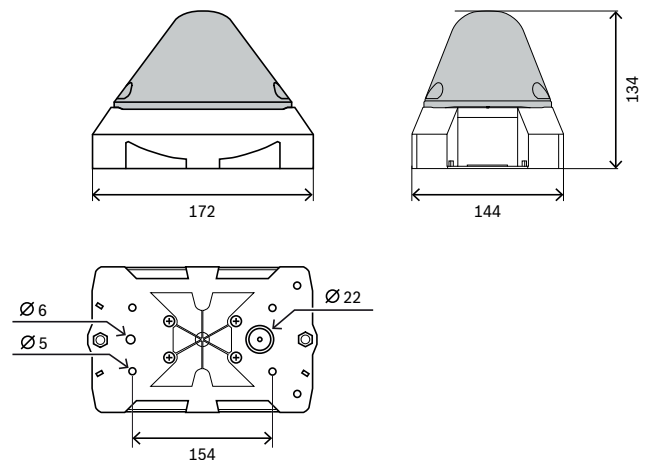

- The device is certified regarding EN 54-23, category C (ceiling), category W (wall) and category O (open device).
- Use the Bosch Safety Systems Designer for reliable planning.

#### Industrial strobe SSM, red

- Maximum mounting height:
  - Wall: 5,6 m
  - Ceiling 7 m
- Illumination area:
  - Wall: 14 m x 7 m
  - Ceiling: 14 m x 11,2 m

#### Industrial strobe SSM, white

- Maximum mounting height:
  - Wall: 9 m

- Ceiling 10 m
- Illumination area:
  - Wall: 22,5 m x 10 m
  - Ceiling: 22,5 m x 18 m

### Technical specifications

#### Electrical

	<b>PY X-M-10-SSM R Industrial strobe SSM, red</b>
Operating voltage (VDC)	18 VDC – 30 VDC
Rated current consumption	464 mA (at 24 VDC at 1 Hz) 282 mA (at 24 VDC at 0,5 Hz)
Inrush current reduction	SM module, limit to max. 4,5 A

	<b>PY X-M-10-SSM W Industrial strobe SSM, white</b>
Operating voltage (VDC)	18 VDC – 30 VDC
Rated current consumption	464 mA (at 24 VDC at 1 Hz) 282 mA (at 24 VDC at 0,5 Hz)
Inrush current reduction	SM module, limit to max. 4,5 A

#### Optical

	<b>PY X-M-10-SSM R Industrial strobe SSM, red</b>
Lightning energy (J)	10 J
Luminous intensity (cd)	54 cd
Flash rate (Hz)	0.1 Hz; 0.5 Hz; 0.75 Hz; 1.0 Hz

	<b>PY X-M-10-SSM W Industrial strobe SSM, white</b>
Lightning energy (J)	10 J
Luminous intensity (cd)	149 cd
Flash rate (Hz)	0.1 Hz; 0.5 Hz; 0.75 Hz; 1.0 Hz

#### Environmental

	<b>PY X-M-10-SSM R Industrial strobe SSM, red</b>
Operating temperature (°C)	-40 °C – 55 °C
Operating relative humidity, non-condensing (%)	0% – 90%
IP rating	IP66

	<b>PY X-M-10-SSM R Industrial strobe SSM, red</b>
Impact protection (EN 50102)	IK08

	<b>PY X-M-10-SSM W Industrial strobe SSM, white</b>
Operating temperature (°C)	-40 °C – 55 °C
Operating relative humidity, non-condensing (%)	0% – 90%
IP rating	IP66
Impact protection (EN 50102)	IK08

#### Mechanical

	<b>PY X-M-10-SSM R Industrial strobe SSM, red</b>
Material	Plastic
Housing color	Red
Cover color	Red
Dimension (H x W x D) (mm)	124 mm x 166 mm x 114 mm

	<b>PY X-M-10-SSM W Industrial strobe SSM, white</b>
Material	Plastic
Housing color	Red
Cover color	Clear
Dimension (H x W x D) (mm)	124 mm x 166 mm x 114 mm

### Ordering information

#### **PY X-M-10-SSM R Industrial strobe SSM, red**

Universally applicable strobe for fire alarm and security technology, red, 10J, IP66, 24V DC, EN 54-23 compliant. Order number **PY X-M-10-SSM R | F.01U.393.220**

#### **PY X-M-10-SSM W Industrial strobe SSM, white**

Universally applicable strobe for fire alarm and security technology, white, 10J, IP66, 24V DC, EN 54-23 compliant. Order number **PY X-M-10-SSM W | F.01U.393.221**

**Represented by:**

**Europe, Middle East, Africa:**

Bosch Security Systems B.V.  
P.O. Box 80002  
5600 JB Eindhoven, The Netherlands  
Phone: + 31 40 2577 284  
[www.boschsecurity.com/xc/en/contact/](http://www.boschsecurity.com/xc/en/contact/)  
[www.boschsecurity.com](http://www.boschsecurity.com)

**Germany:**

Bosch Sicherheitssysteme GmbH  
Robert-Bosch-Ring 5  
85630 Grasbrunn  
Tel.: +49 (0)89 6290 0  
Fax: +49 (0)89 6290 1020  
[de.securitysystems@bosch.com](mailto:de.securitysystems@bosch.com)  
[www.boschsecurity.com](http://www.boschsecurity.com)

**North America:**

Bosch Security Systems, LLC  
130 Perinton Parkway  
Fairport, New York, 14450, USA  
Phone: +1 800 289 0096  
Fax: +1 585 223 9180  
[onlinehelp@us.bosch.com](mailto:onlinehelp@us.bosch.com)  
[www.boschsecurity.com](http://www.boschsecurity.com)

**Asia-Pacific:**

Robert Bosch (SEA) Pte Ltd, Security Systems  
11 Bishan Street 21  
Singapore 573943  
Phone: +65 6571 2808  
Fax: +65 6571 2699  
[www.boschsecurity.com/xc/en/contact/](http://www.boschsecurity.com/xc/en/contact/)  
[www.boschsecurity.com](http://www.boschsecurity.com)