

Installation Instructions for the DS7460i Dual Zone Input Module

1.0 Description

The DS7460i is a Dual Zone Input Module designed to operate with compatible multiplex systems. It provides two supervised input zones for connection of conventional normally open or normally closed contacts. Each DS7460i occupies two multiplex zone addresses on the system and can monitor up to two separate zones. The DS7460i connects to the DS7430 or DS7436 Multiplex Expansion Modules or the D8125MUX Multiplex Expansion Module.

For additional information about installing the DS7460i, refer to the *D9412GV2/D7412GV2 Approved Applications Compliance Guide* (P/N: F01U003639).

2.0 Specifications

i *The DS7460i is compatible with the D8125MUX (P/N: F01U034973).*

- **Voltage:** 12 VDC nominal
- **Current:** 1 mA maximum
- **Line Impedance:**

Maximum Impedance: 4.05Ω at +68°F (+20°C) nominal		
Maximum Distance	Size	
250 ft	22 AWG	
600 ft	18 AWG	
76 m	0.65 mm	
193 m	1.02 mm	
Fire applications require 18 AWG.		

- **Operating Temperature Range:** +32°F to +122°F (0°C to +50°C)
- **Signaling Line Circuit Type:** Class B (Style 4)
- **Initiating Device Circuit Type:** Class B (Style A)
- **Relative Humidity:** 0 to 93%

i *When used in a fire alarm system, NFPA 72 prohibits this product from sharing a communication bus with non-fire devices.*

3.0 Programming

Consult the intended control panel's installation guide for multiplex zone (point) programming information.

i *Each DS7460i will require two multiplex addresses.*

See page 3 for switch settings.

4.0 Installation

These Installation Instructions assume the control panel is installed and in proper working condition.

i *The control panel (or D8125MUX) must be programmed and the DS7460i address switches must be set for the DS7460i to operate.*

Program the control panel (or D8125MUX) as described in the control panel's reference guide.



Disconnect power to the panel before running wires to connect the DS7460i.



After any programming or hardware change, do a functional test of the system as required by local codes.

Remove the cover of the DS7460i. Press in and up with your thumb and nail directly above the lip of the DS7460i (see Figure 1).

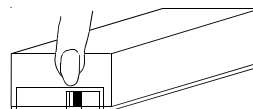

Figure 1: Removing the Cover

Remove the DS7460i circuit board from the base. Press the circuit board retainer tab and pull the circuit board up and out of the base (see Figure 2).

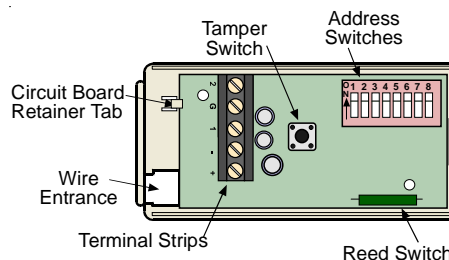

Figure 2: Removing the PCB



Handle this and all circuit boards carefully. Hold the board by its edges.

- Route the wiring through the wire entrance of the DS7460i base.
- Mount the DS7460i base to the mounting surface using the supplied screws.
- Return the DS7460i circuit board to the base.

5.0 Wiring

DS7460i Terminals	Description
2	Protection Zone 2 Input
G	Protection Zone Ground (Common)
1	Protection Zone 1 Input
-	Multiplex Bus Negative
+	Multiplex Bus Positive

Table 1: DS7460i Terminal Descriptions



The input zones are power limited and supervised.



When used in fire applications, Normally Open contacts must be used on the input zones.



BOSCH

Connect wiring to the DS7460i as shown in Figures 4-6. Protection zones are designed to monitor Normally Open or Normally Closed dry contacts. They are supervised using 47 kilohm end-of-line resistors.

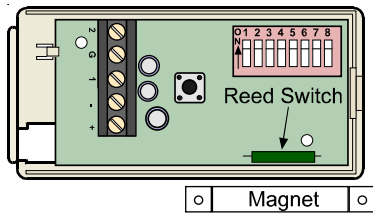

Figure 3: Location of magnet

i Zone 1 may be used as a magnetic contact by mounting a magnet in conjunction with the reed switch and removing the EOL resistor for Zone 1. Zone 1 may not be used as a magnetic contact and used to monitor other contacts at the same time.

It may be desirable to cut the reed switch from the DS7460i circuit board if it is not being used. This will eliminate possible tampering to override Zone 1 operation.

For fire installations, order Multiplex Fire Zone EOL P/N: 28010 in the quantity needed.

5.1 DS7430 Multiplex Expansion Module Wiring

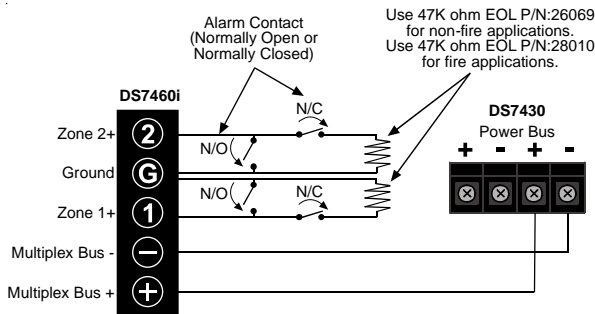

Figure 4: Wiring using a DS7430 Multiplex Expansion Module

5.2 DS7436 Multiplex Expansion Module Wiring

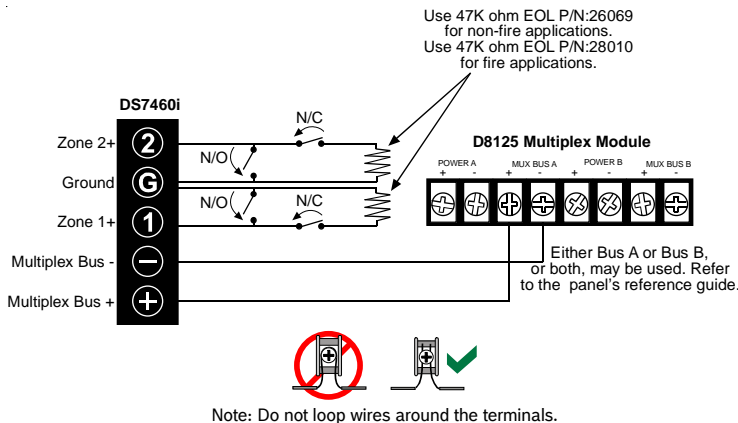

Figure 5: Wiring using a DS7436 Multiplex Expansion Module

5.3 D8125MUX Multiplex Expansion Module Wiring

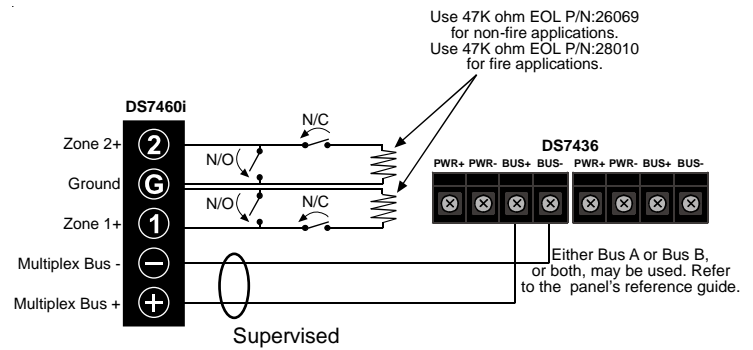

Figure 6: Wiring the D8125MUX Multiplex Expansion Module

i For UL Listed fire installations, Normally Open (N/O) contacts must be used.

6.0 Switch Settings

Set the address switch settings before connecting the DS7460i to the multiplex bus.

i No two DS7460i Dual Zone modules may be set to the same address. Having two or more units set to the same address may prevent fault detection or cause multiplex bus failure.

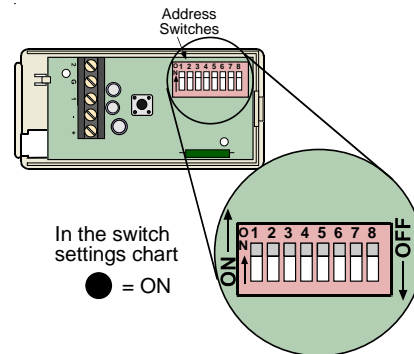

Figure 7: Address Switches

You can find the Address Switch Settings using the chart on this page, or by calculating the decimal number of the address.

0	1	2	3	4	5	6	7	8
ON	ON	ON	ON	ON	ON	ON	ON	ON
128	64	32	16	8	4	2	1	
Binary Switch Values (Point 17 shown)								

i Zone (Point) addresses 001-008 may not be used for multiplex zones on the DS7400Xi.

● = SWITCH ON (CLOSED)

ZONE (POINT) ADDRESS	SWITCH NUMBER							
	1	2	3	4	5	6	7	8
001/002								●
003/004							●	●
005/006						●		●
007/008						●	●	●
009/010								●
011/012					●		●	●
013/014					●	●		●
015/016					●	●	●	●
017/018				●				●
019/020				●			●	●
021/022				●		●		●
023/024				●		●	●	●
025/026				●	●			●
027/028				●	●		●	●
029/030				●	●	●		●
031/032				●	●	●	●	●
033/034		●						●
035/036		●					●	●
037/038		●				●		●
039/040		●				●	●	●
041/042		●		●				●
043/044		●		●			●	●
045/046		●		●			●	●
047/048		●		●	●	●		●
049/050		●	●					●
051/052		●	●				●	●
053/054		●	●			●		●
055/056		●	●			●	●	●
057/058		●	●	●				●
059/060		●	●	●			●	●
061/062		●	●	●	●			●
063/064		●	●	●	●	●		●
065/066	●							●
067/068	●							●
069/070	●					●		●
071/072	●					●	●	●
073/074	●				●			●
075/076	●				●			●
077/078	●				●	●		●
079/080	●				●	●	●	●
081/082	●			●				●
083/084	●			●				●
085/086	●			●			●	●
087/088	●			●			●	●
089/090	●			●	●			●
091/092	●			●	●			●
093/094	●			●	●	●		●
095/096	●			●	●	●	●	●
097/098	●	●						●
099/100	●	●						●
101/102	●	●					●	●
103/104	●	●					●	●
105/106	●	●			●			●
107/108	●	●			●			●
109/110	●	●			●	●		●
111/112	●	●			●	●	●	●
113/114	●	●			●	●		●
115/116	●	●			●	●		●
117/118	●	●			●	●		●
119/120	●	●			●	●	●	●
121/122	●	●			●	●		●
123/124	●	●			●	●		●
125/126	●	●			●	●		●
127/128	●	●			●	●		●

● = SWITCH ON (CLOSED)

ZONE (POINT) ADDRESS	SWITCH NUMBER							
	1	2	3	4	5	6	7	8
129/130	●							●
131/132	●						●	●
133/134	●					●		●
135/136	●					●	●	●
137/138	●				●			●
139/140	●				●		●	●
141/142	●				●	●		●
143/144	●				●	●	●	●
145/146	●			●				●
147/148	●			●			●	●
149/150	●			●		●		●
151/152	●			●		●	●	●
153/154	●			●	●			●
155/156	●			●	●		●	●
157/158	●			●	●	●		●
159/160	●			●	●	●	●	●
161/162	●	●						●
163/164	●	●					●	●
165/166	●	●					●	●
167/168	●	●					●	●
169/170	●	●			●			●
171/172	●	●			●		●	●
173/174	●	●			●		●	●
175/176	●	●			●	●	●	●
177/178	●	●	●					●
179/180	●	●	●				●	●
181/182	●	●	●				●	●
183/184	●	●	●				●	●
185/186	●	●	●	●				●
187/188	●	●	●	●			●	●
189/190	●	●	●	●	●			●
191/192	●	●	●	●	●	●		●
193/194	●	●						●
195/196	●	●					●	●
197/198	●	●					●	●
199/200	●	●					●	●
201/202	●	●				●		●
203/204	●	●				●		●
205/206	●	●				●	●	●
207/208	●	●				●	●	●
209/210	●	●				●		●
211/212	●	●			●			●
213/214	●	●			●		●	●
215/216	●	●			●		●	●
217/218	●	●			●	●		●
219/220	●	●			●	●		●
221/222	●	●			●	●	●	●
223/224	●	●			●	●	●	●
225/226	●	●	●					●
227/228	●	●	●					●
229/230	●	●	●				●	●
231/232	●	●	●				●	●
233/234	●	●	●				●	●
235/236	●	●	●				●	●
237/238	●	●	●				●	●
239/240	●	●	●				●	●
241/242	●	●	●	●				●
243/244	●	●	●	●				●
245/246	●	●	●	●				●
247/248	●	●	●	●			●	●
249/250	●	●	●	●			●	●
251/252	●	●	●	●			●	●
253/254	●	●	●	●			●	●
255/256	●	●	●	●			●	●

