

LC20-PC60G6-6E Premium sound 60 W 6"ceiling lsp (2 pcs)

www.boschsecurity.com



BOSCH
Invented for life



- ▶ Long throw 6.5 inch (165 mm) woofer housed in a large vented steel enclosure for extended LF performance down to 50 Hz
- ▶ 100 watt power handling provides for 95 dB maximum SPL
- ▶ High output true compression driver for wide dispersion and superior coverage control out to 20 kHz
- ▶ Front baffle transformer tap adjustment switch
- ▶ EN 54-24

The LC20-PC60G6-6E speaker system from Bosch is a complete high performance two-way ceiling speaker package. The LC20-PC60G6-6E is ideal for background and foreground music, voice evacuation, paging, and sound reinforcement applications. The Premium Ceiling Speaker provides a unique combination of high acoustic output, superb coverage control, high power handling and wide dispersion, to cover virtually any size listening area. The LC20-PC60G6-6E comes completely assembled with an integrated bezel assembly, grille, rear enclosure, 6.5-inch (165 mm) coaxial two-way speaker and internal high power line-matching transformer. The speaker features a waveguide coupled true compression HF driver and a long excursion 6.5-inch (165 mm) woofer. The LC20-PC60G6-6E utilizes a transformer that offers a selection of 7.5 W (70-V only), 15, 30 or 60 watts delivered to the speaker system using either 70-V or 100-V lines, or 8 ohm bypass. Selection is via a convenient switch on the front baffle. The perforated grille is fully zinc plated and finished in semi-gloss white powder-coated enamel. The baffle and bezel are constructed from fire rated ABS. The rear enclosure is constructed from zinc-plated, heavy gauge steel. The

rear enclosure, with fiberglass damping material, provides an optimum internal volume for extended low-frequency performance. A rear cover, with provisions for a junction box fitting, provides access to a 4-pin terminal block that allows direct connection to the speaker with up to 12 gauge wire and provides pass through to additional speakers. For special voice evacuation installations a ceramic terminal block is provided and attaches to the speaker back can enclosure under the rear connector cover. The rear input cover for EN54 is used to create a seal to protect the ceiling speaker from moisture and foreign particles, if properly installed. The weatherized terminal cover must be used in all EN54 installations. Two adjustable metal tile bridges and metal "C" ring are included for safe suspension of the LC20-PC60G6-6E ceiling systems in a drop ceiling that uses mineral wool, or other fiber-based ceiling tiles.

2 | Premium sound 60 W 6"ceiling lsp (2 pcs)

Certifications and approvals

Region	Certification
Europe	DOP
	CE

Parts included

Quantity	Component
2	Speaker systems
4	Tile rails
2	C-ring supports
2	Grilles
1	Installation note
1	Cutout template
4	Support ring screws
2	Terminal connectors
2	Ceramic blocks
2	Weatherized terminal covers
2	Gland nuts
8	Screws

Technical specifications

Frequency Range (-10 db):	50 Hz – 20 kHz
Nominal Coverage (Conical):	100°
Power Handling (Direct Coupled):	200 W Program, 100 W Pink Noise as per EN54-24 standard
Sensitivity per EN54-24 standard (SPL 1 W/4 m):	75 dB
Max Calculated SPL per EN54-24 standard:	60 watt Transformer coupled @ 4 meters: 92 dB 100 watt Direct coupled @ 4 meters: 95 dB
Impedance:	Direct Coupled: 8 ohms 70V Transformer Coupled: 60 watt/83Ω, 30 watt/167Ω, 15 watt/333Ω, 7.5 watt/667Ω 100v Transformer Coupled: 60watt/167Ω, 30 watt/333Ω, 15 watt/667Ω
LF Transducer:	165 mm (6.5 in)
HF Transducer:	35 mm Compression Driver
Transformer Taps:	70V: 60W, 30W, 15W, 7.5W, 8 ohm 100V: 60W, 30W, 15W, 8 ohm

Connectors:	Removable locking 4-pin (Phoenix) 2.5 mm (12 AWG) max wire size
Enclosure:	ABS Plastic (UL94V-0) Baffle, steel back can
Color:	White
Grille:	Color matched steel grille with fabric
Dimensions (H x Dia):	294 mm x 280 mm (11.57 in x 11.0 in)
Cutout Size:	248 mm (9.76 in)
Net Weight:	7.33 kg (16.15 lb)
Shipping Weight: (pair)	17.51 kg (38.6 lb)
Support Hardware:	C Ring, Tile Bridge, Weatherized Terminal Cover
Approvals:	UL1480, 2043; CE, EN54-24:2008



Notice

The specifications data was measured in an anechoic chamber according to EN 54-24. Reference axis: Axis is on the center of grille surface and perpendicular to the grille surface. Reference plane: Plane is on the grille surface and perpendicular to the reference axis. Horizontal plane: Plane is containing the reference axis and perpendicular to the reference plane.

 0359
Bosch Security Systems Inc. 130 Perinton Pkwy, Fairport, NY, 14450, USA 17 0359-CPR-00615
EN 54-24:2008 Loudspeaker for voice alarm systems for fire detection and fire alarm systems for buildings Ceiling loudspeakers LC20-PC60G6-6E, LC20-PC60G6-8E Type A See product manual F.01U.321.490 for further equalization and installation information.

Equalization:

When used in an EN54 installation the following equalization must be applied to the speakers:

LC20-PC60G6-6E	LC20-PC60G6-8E
PEQ Frequency: 180 Hz	PEQ Frequency: 152 Hz
PEQ Filter Q: 2.0	PEQ Filter Q: 2.0
PEQ Gain: -6.0 dB	PEQ Gain: -8.0 dB

Frequency response and impedance:

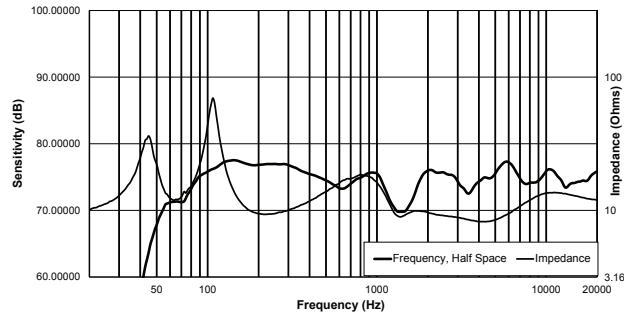

Frequency Response and Impedance 1 watt/4 meter/on axis (With EN54 required equalization applied)

Beamwidth:

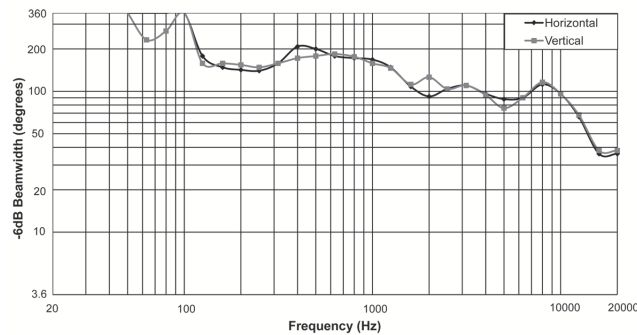

Directivity:

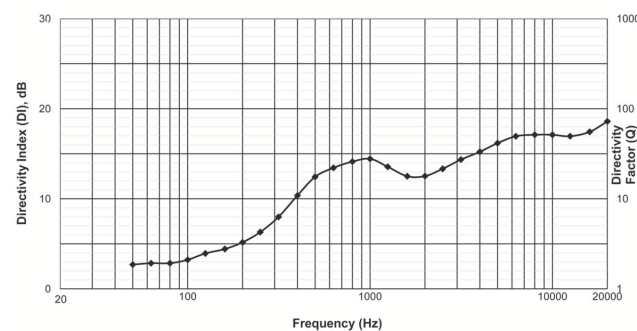

Represented by:

Europe, Middle East, Africa:
 Bosch Security Systems B.V.
 P.O. Box 80002
 5600 JB Eindhoven, The Netherlands
 Phone: + 31 40 2577 284
 emea.securitysystems@bosch.com
 emea.boschsecurity.com

Germany:
 Bosch Sicherheitssysteme GmbH
 Robert-Bosch-Ring 5
 85630 Grasbrunn
 Germany
 www.boschsecurity.com

North America:
 Bosch Security Systems, Inc.
 130 Perinton Parkway
 Fairport, New York, 14450, USA
 Phone: +1 800 289 0096
 Fax: +1 585 223 9180
 onlinehelp@us.bosch.com
 www.boschsecurity.us

Asia-Pacific:
 Robert Bosch (SEA) Pte Ltd, Security Systems
 11 Bishan Street 21
 Singapore 573943
 Phone: +65 6571 2808
 Fax: +65 6571 2699
 apr.securitysystems@bosch.com
 www.boschsecurity.asia

Dimensions:

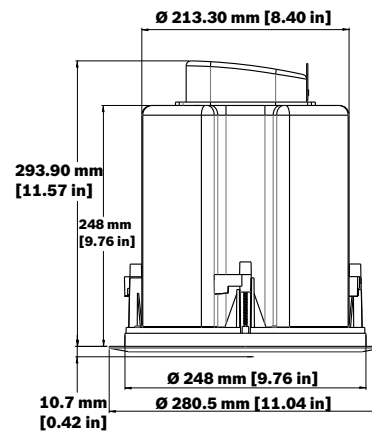

Architectural and engineering specifications:

The LC20-PC60G6-6E speaker system shall be comprised of a UL 94V-0 fire rated ABS baffle/bezel assembly, zinc plated steel rear enclosure, powder coated grille with safety tether, transformer with 8 ohm bypass, and 6.5-inch long excursion low frequency transducer with coaxially-mounted true compression HF driver. The speaker shall meet the following criteria: power rating shall be 100 watts of IEC 268-5 pink noise (6 dB crest factor). Frequency response, uniform from 50 Hz - 20 kHz. Pressure sensitivity, 87 dB SPL at 1 meter (3.3 feet) on axis with 1 watt of pink noise (ref. 20µPa). The speaker shall be 294 mm (11.57 in) deep and 280 mm (11.0 in) in diameter. Weight shall be 7.33 kg (16.15 lb). The coaxial ceiling speaker shall be the model LC20-PC60G6-6E from Bosch.

Ordering information

Premium sound 60 W 6"ceiling lsp (2 pcs)

Ultra high performance 6" two-way ceiling mount loudspeaker system with concentric compression driver and integrated housing and mounting system (set of 2 pcs), EN 54-24 certified, white
 Order number **LC20-PC60G6-6E**