

AVIOTEC IP starlight 8000

FCS-8000-VFD-B / Firmware 7.8x

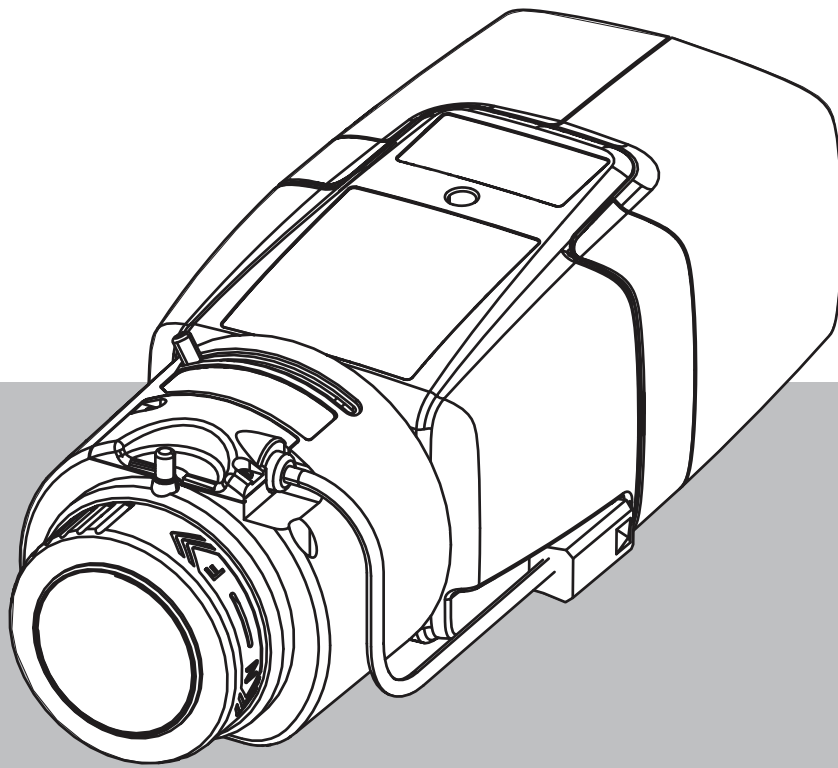

Table of contents

1	Safety instructions	5
1.1	General Safety Messages / Notices	5
2	Introduction	9
2.1	Disclaimer	9
2.2	About this manual	9
2.3	Conventions in this manual	9
2.4	Definition of optical terms	9
2.4.1	Illumination	10
2.4.2	Focal length	10
2.4.3	Monitoring Area	11
2.4.4	Different angle types	11
3	System Overview	14
3.1	Algorithm	14
3.1.1	Flame detection characteristics	14
3.1.2	Smoke detection characteristics	15
4	Planning	19
4.1	Application basics of video-based fire detection	19
4.1.1	Protection objective - Area monitoring	19
4.1.2	Protection objective - Area-Of-Interest	19
4.2	Flame/smoke sizes (50/75 cm)	19
4.3	Check list	19
4.4	Influencing factors at the installation site (indoor)	21
4.5	Influencing factors at the installation site (outdoor)	24
4.6	Minimum distances	26
4.6.1	Indoor	26
4.6.2	Outdoor	27
4.7	Maximum distances	28
4.7.1	Indoor	28
4.7.2	Outdoor	29
4.8	Image margin area	30
4.9	Immediate environment of the camera	31
4.9.1	Illumination and brightness	31
4.9.2	Infrared (IR) illumination	32
4.9.3	Privacy protection	32
5	Camera integration	33
5.1	Local Area Network	34
5.2	Local Area Network with recording solution	34
5.3	Monitoring Center	34
5.4	Fire Alarm Control Panel	35
5.5	Mobile Devices	36
6	Use cases	38
6.1	Fire detection only	38
6.2	Fire detection and VCA profiles	38
6.3	Scheduled fire detection	38
6.4	External trigger to switch fire detection mode	39
7	Technical data	41
8	Troubleshooting	43
8.1	False Alarms	43

8.1.1	Quick solution to solve false alarms	43
8.1.2	False alarms under 4 seconds concerning the whole detection area	43
8.1.3	False alarms at small constant areas	43
8.1.4	Vibrations at the camera site	43
8.2	No alarm transmission	44
8.3	No fire detection	44
8.4	Image quality	44
8.5	Camera	44
9	Appendices	46
9.1	LVF-5005C-S4109 (standard lens)	46
9.1.1	Flame detection	46
9.1.2	Smoke detection	48
9.2	LVF-8008C-P0413	50
9.2.1	Flame detection	50
9.2.2	Smoke detection	52

1 Safety instructions

In this document, the following symbols and notations are used to draw attention to special situations:

**Danger!**

Indicates a hazardous situation which, if not avoided, will result in death or serious injury.

**Warning!**

Indicates a hazardous situation which, if not avoided, could result in death or serious injury.

**Caution!**

Indicates a hazardous situation which, if not avoided, could result in minor or moderate injury.

**Notice!**

Indicates a situation which, if not avoided, could result in damage to the equipment or environment, or data loss.

1.1 General Safety Messages / Notices

**Warning!**

Do not moisten the electronic appliances inside of the lens.
It may cause fire or electric shock. In this case, shut off the power supplied to the lens immediately.

**Caution!**

The Low Voltage power supply unit must comply with EN/UL 60950. The power supply must be a SELV-LPS unit or a SELV - Class 2 unit (Safety Extra Low Voltage - Limited Power Source).

**Caution!**

Installation should only be performed by qualified service personnel in accordance with the National Electrical Code (NEC 800 CEC Section 60) or applicable local codes.

**Caution!**

Do not leave or store the lens under direct sunshine.
The lens may focus rays of light on a near-by object and cause fire.

**Caution!**

In case of unusual behavior, smoke, noise or smell coming out of the lens, shut off the power immediately and pull out the lens cable.
Notify the installer or sales agent from which you purchased the product.

**Caution!**

Make sure to test the fire detection after updating to the latest firmware.

**Notice!**

Avoid obstructions in the field of view!

Covered fires cannot be detected correctly. An unobstructed view of the detection area is necessary.

**Notice!**

Activating video-based fire detection sets camera settings to a specific preset.

This preset affects several camera settings as long as this mode is activated.

**Notice!**

No detection of moving fire.

Moving fires will not be detected by the video-based fire detection.

**Notice!**

No direct connection to fire services in EN54 compliant installations.

Authorities can allow a connection to fire services after verifying alarms in a monitoring center.

**Notice!**

Minimum Illumination required.

To ensure the proper functioning of the video-based fire detection algorithm, a minimal illumination of 2 lx is required. If the illumination is less than 2 lx, an additional IR illumination is required.

**Notice!**

Influencing factor wind conditions

Strong air currents can cause false alarms by raising dust or debris similar in appearance to fire and smoke.

**Notice!**

Respect data protection.

The relevant data protection and privacy rules are to be complied with.

**Notice!**

Avoid backlight.

Backlight can disturb the video-based fire detection algorithm.

**Notice!**

Optimized smoke detection.

The video-based fire detection algorithm is optimized for smoke of smoldering fires.

**Notice!**

Qualified personnel only.
Assembly and installation must only be performed by qualified personnel.

**Notice!**

Reduced detection distances at image margin area.
Due to optical distortion of the lens, the maximum detection distances at the image margin area are reduced.

**Notice!**

Avoid image regions with continuous upward motion.
Continuous upward motion might lead to false alarms.

**Notice!**

Make sure the camera is firmly mounted.
Camera shake might lead to false alarms. Avoid vibrations of the camera and the camera environment.

**Notice!**

No detection of irregular expanding smoke.
Smoke plumes must move in a constant direction with a minimum density to be detected by the video-based fire detection.

**Notice!**

Ensure that you are always using the latest version of the operation manual and the current camera firmware. The manufacturer will not be held liable for any damages resulting from the use of older versions.

**Notice!**

No detection in blinking light regions in the detection area.

**Notice!**

Only use the supplied lens or approved lenses.
Do not use other lenses. A reliable functioning of the product cannot be guaranteed with other lenses.

**Notice!**

Bright areas in the background (e.g., white areas, sun or sky) limit the detection of flames or can lead to flames not being detected.

**Notice!**

Flame-colored background in the picture is to be avoided, since a reliable detection cannot be ensured!

**Notice!**

The system is developed for areas with white illumination (warm white 3000 K - daylight white 5600 K). In case of different illumination it might be necessary to use the Expert mode (not VdS-certified) to ensure the flame detection. Fire detection must be tested to evaluate proper functionality of the system with the used illumination.

2 Introduction

2.1 Disclaimer

IMPORTANT: Video fire indication systems are video content analysis systems. They give indications for possible fires and are designed to supplement fire detection systems and human guards in monitoring centers in order to recognize possible dangerous situations. Video fire indication systems are confronted with a higher amount of challenges considering scenery and background compared to conventional fire detection systems. They cannot ensure that fire will be detected reliably in all scenery settings. Thus, the video fire detection system shall be seen as a support system that enhances the probability of early fire detection, with the restriction that it shall not be seen as a system that ensures fire detection in all possible image scenarios and it might detect false alarms. Conventional fire alarm systems must in no way be replaced by video-based fire alarm systems.

In addition, and for the U.S. market only, Bosch Security Systems makes no representation that the video fire indication system will prevent any personal injury or property loss by fire or otherwise; or that such product will in all cases provide adequate warning or protection. Buyer understands that a properly installed and maintained fire indication system may only reduce the risk of a fire or other events occurring without providing an alarm, but it is not insurance or a guarantee that such will not occur or that there will be no personal injury or property loss as a result.

Consequently, Bosch Security Systems shall have no liability for any personal injury, property damage or other loss based on a claim the product failed to give warning.

2.2 About this manual

This manual has been compiled with great care and the information it contains has been thoroughly verified. The text was correct at the time of printing, however, the content can change without notice. The manufacturer accepts no liability for damage resulting directly or indirectly from faults, incompleteness or discrepancies between this manual and the product described.

All hardware and software product names used in this document are likely to be registered trademarks and must be treated accordingly.

The operation manual provides an overview of possibilities and fields of application of the video-based fire detection. It should be a guideline for customer-specific application planning.

2.3 Conventions in this manual

Terms concerning the adjustment of the smoke and flame algorithm, such as menu options, commands or text in the user interface, are written in bold.

2.4 Definition of optical terms

The reflected light coming from the field of view arrives at the camera lens. The image sensor of the camera transforms the light into electric signals. This electrical image is the basis for further data processing. This chapter contains basic descriptions of optical terms.

2.4.1 Illumination



Notice!

Different illumination levels can lead to different detection speeds. The poorer the ambient illumination, the less the smoke stands out against the background. For this reason, poor lighting < 7 lx may require a higher smoke density for reliable smoke detection.

Illumination is an important influencing factor for sensible optical systems. Natural light shows the huge range of illumination values from direct sunlight (~100.000 lx) to full moon on a clear night (~1.0 lx).

The following table provides an overview of typical illumination values in different application areas:

Application Area	Illumination (in lx)
Storage facility	50
Process plants	200
Sales room	300
Office space	500

In general a uniformly illuminated monitoring area is advantageous for the video-based fire detection. Backlight should be avoided.

The illumination is measured using a luxmeter in the application at a height of 1 meter with the sensor pointing vertically upwards.

Dynamic range

The dynamic range is the ratio between the darkest spot compared to the lightest spot in the application. Use a luxmeter to determine the brightness in your application. The dynamic range in the camera image / the detection area must be equal or less than factor 5.

2.4.2 Focal length

The focal length of an optical system defines the distance between a light refracting lens and the focal point. Field of view, maximum distance and field angle are dependant as shown in the graphic below.

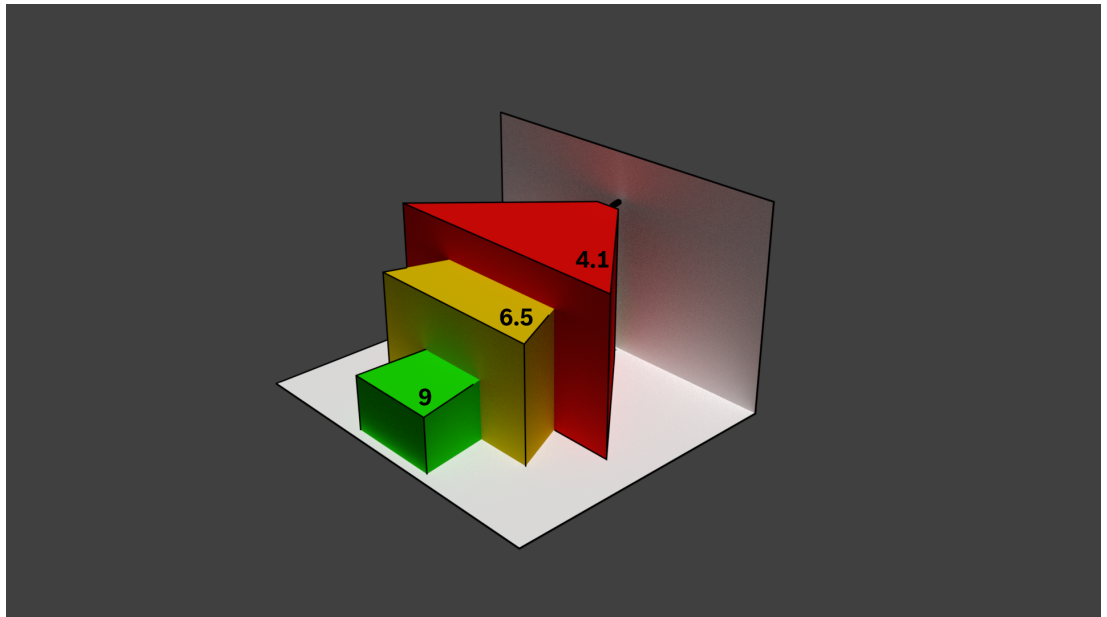

The maximum width of the field of view may be realized by the minimum focal length. This adversely affects the maximum distance to a detectable fire (red).
 The maximum distance to a detectable fire may be reached by adjusting the largest focal length which decreases the width of the field of view to the minimum (green).

2.4.3 Monitoring Area

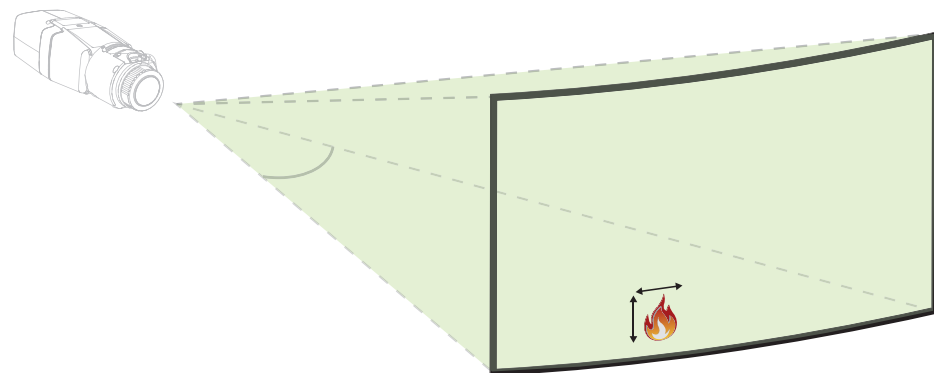

The monitoring area defines the effective space that can be observed by the video-based fire detection. It is depending on the setting of the camera lens.

2.4.4 Different angle types

There are different types of angles influencing the set-up of the camera. The following overview helps to get a better understanding of angles which are important for the video-based fire detection.

Angle between ground and line of sight

The angle between a fire on the ground and the line of sight to the camera is important for the flame and smoke detection. This angle needs to be 37.5° or less, otherwise flame or smoke will not be detected.

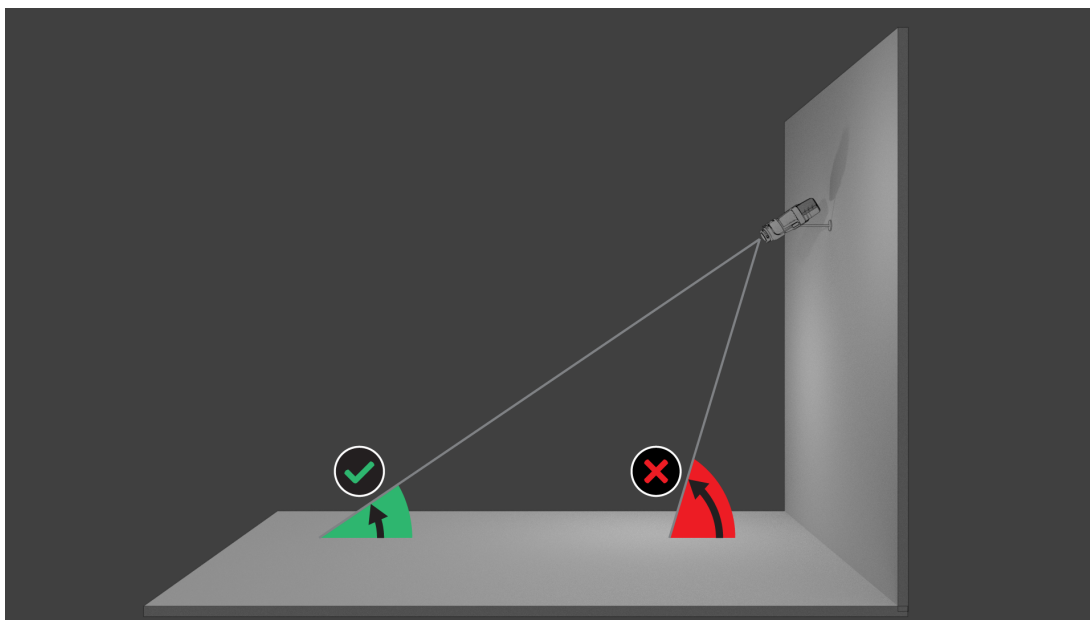

Opening angle of the lens

The opening angle of the lens can be set from wide-angle to telephoto setting. This influences the field of view of the camera.

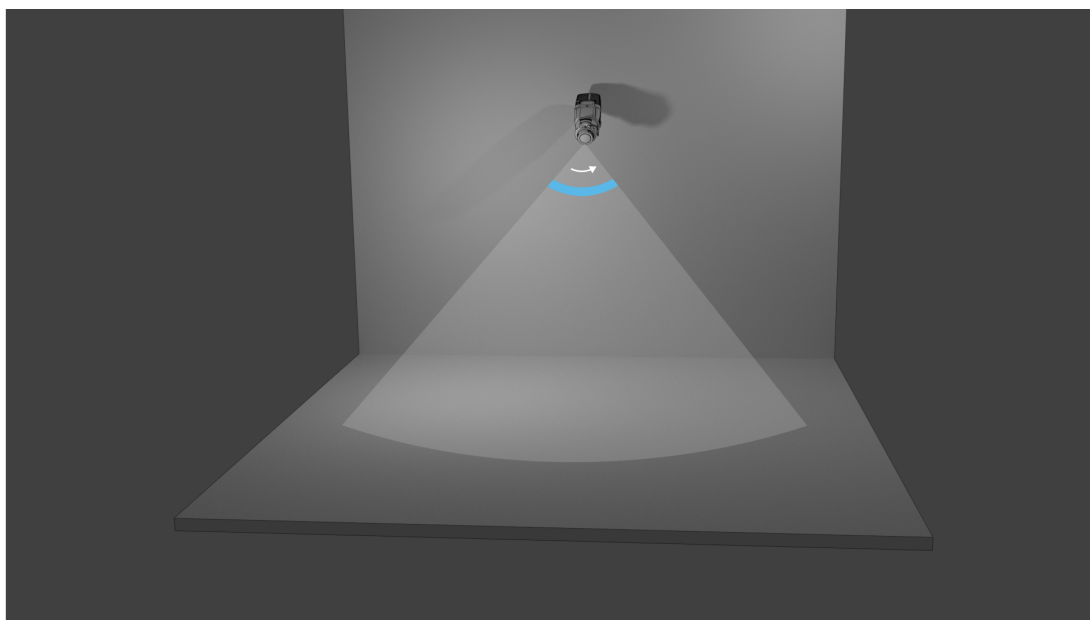

Angle for vertical alignment of the camera

The vertical alignment of the camera is also important for the video-based fire detection. A flat angle is recommended.

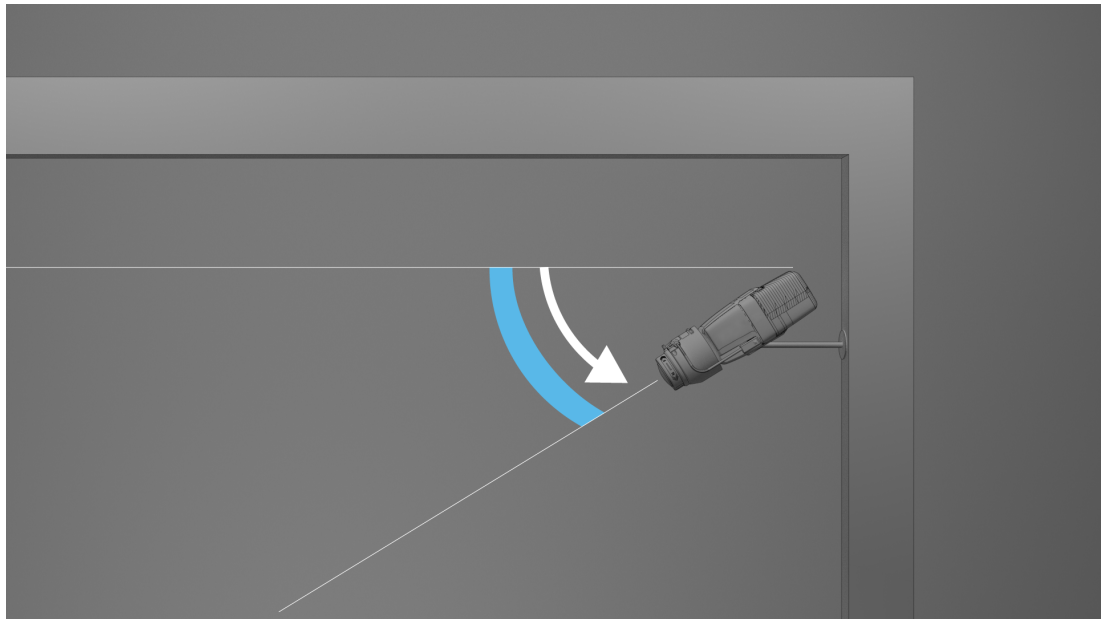
**Angle for horizontal alignment of the camera**

Align the camera according to your application by adjusting the angle of the horizontal alignment of the camera.

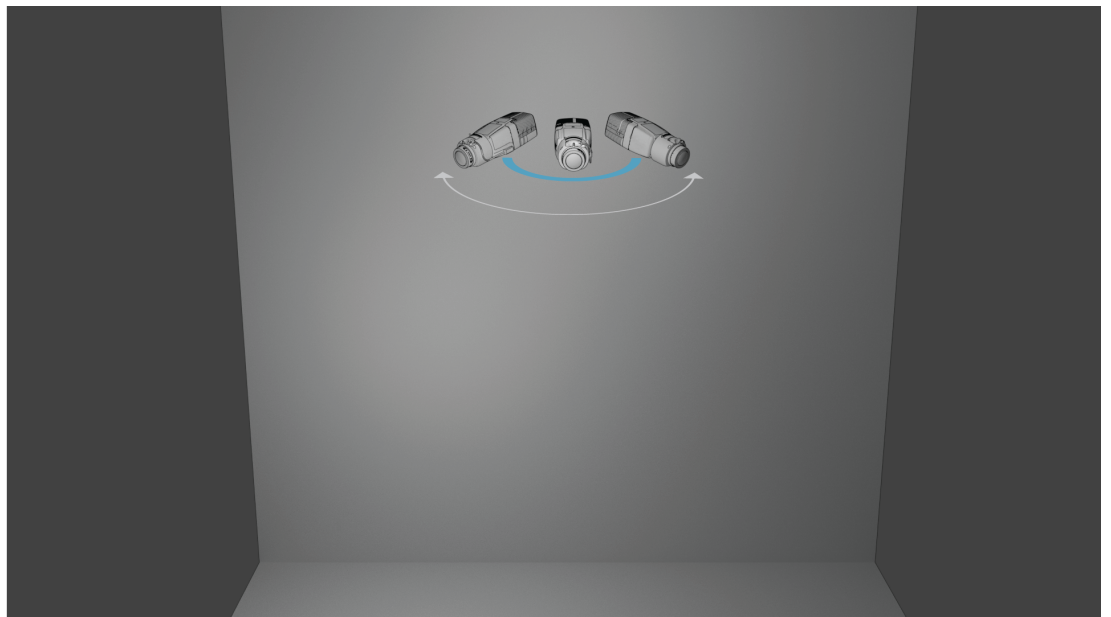

3 System Overview

The video-based fire detection is the system of choice when reliable video motion and fire detection is needed, e.g. applications which are not subjected to construction product regulation or a supplementation to existing fire detection systems. AVIOTEC IP starlight 8000 operates as stand-alone unit and doesn't need a separate evaluation unit. Furthermore, it contains all features of the Intelligent Video Analytics which allows analyzing and evaluating moving objects in parallel. Video-based fire detection and Intelligent Video Analytics operate independently from each other and are separately adjustable.

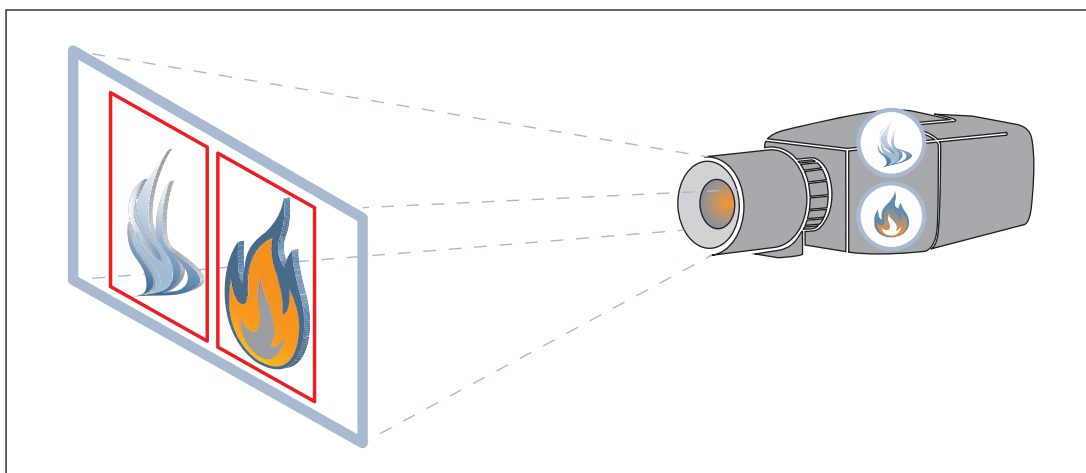

3.1 Algorithm

The intelligent smoke and flame algorithm analyzes video frames by means of characteristic and predefined patterns and variables. The fast detection algorithm is based on a real-time image processing on the camera firmware.

There are factors that can influence this kind of visual fire detection. It is important to avoid obstructions in the field of view. Sometimes obstructions cannot be prevented, e.g. building construction factors or huge machine parts. In this case it is necessary to analyze whether there is any need for further video-based fire detection cameras.

3.1.1 Flame detection characteristics



Notice!

The system is developed for areas with white illumination (warm white 3000 K - daylight white 5600 K). In case of different illumination it might be necessary to use the Expert mode (not VdS-certified) to ensure the flame detection. Fire detection must be tested to evaluate proper functionality of the system with the used illumination.

Flames will be analyzed by means of their behavior. Flickering, brightness and constant illuminated parts of white, yellow or orange are the basis colors (flame colors) for the algorithm to split off the video image into important and unimportant areas. Further flame colors will not be considered, for example a blue flame might not be detected.

Another algorithm characteristic to identify flames is the flickering of a flame. Objects with a similar movement pattern might cause false alarms, e.g. loose fluttering objects. The video-based fire detection offers subsequent adaption of flame detection settings for this purpose. Air turbulence can have an influence on the visibility of the flame core and flickering. E.g., if the flame is moved back and forth too quickly by wind, this can lead to the flame not being detected in the camera image.

3.1.2 Smoke detection characteristics



Notice!

Different illumination levels can lead to different detection speeds. The poorer the ambient illumination, the less the smoke stands out against the background. For this reason, poor lighting < 7 lx may require a higher smoke density for reliable smoke detection.

The video-based fire detection is optimized for smoke of smoldering fires. The algorithm analyzes smoke based on physical characteristics. Typically a plume of smoke is formed in a regular upward motion of smoke at the same position. This is characterized by a thick column of smoke which is directly visible. Speed and angle of smoke may vary. The maximum detectable speed can be found in the chapter Technical data. Only color-neutral smoke (white, grey, black) will be detected by the smoke algorithm.

The area in which the smoke density decreases is called ambient smoke. The smoke motion is not directly visible. Ambient smoke will not be detected.

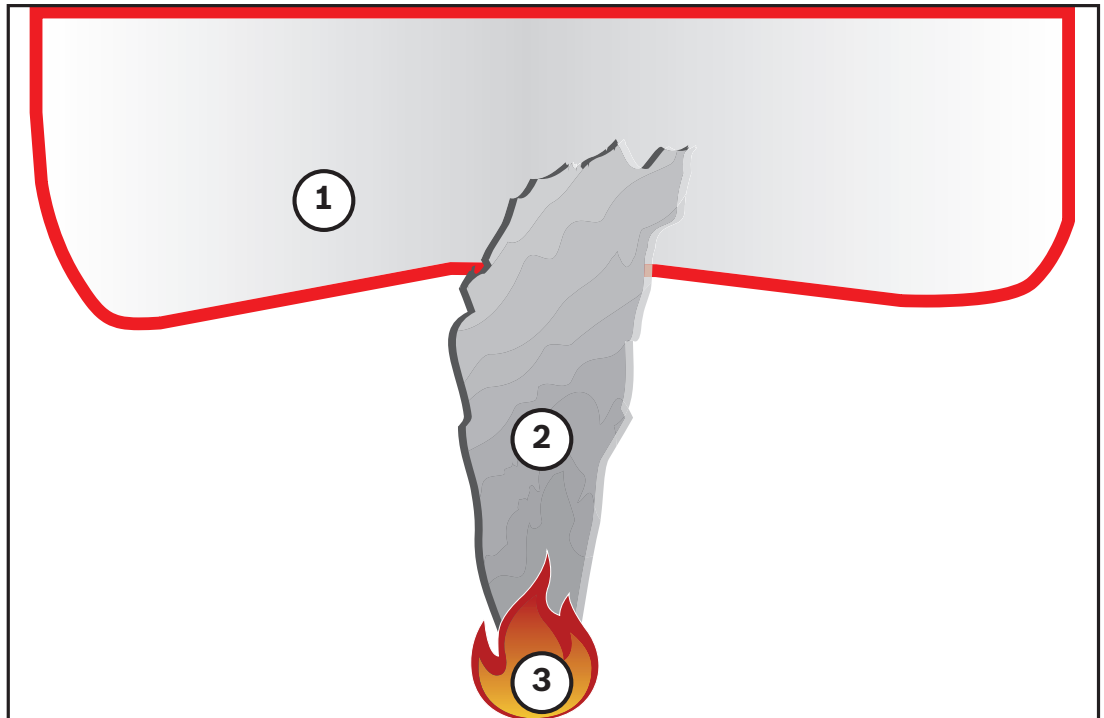

1	Ambient smoke
2	Smoke plume
3	Fire

Minimum and maximum smoke width and motion speed

A minimum speed of smoke is needed together with a minimum width of the smoke plume to be detected by the video-based fire detection. The minimum motion speed of smoke and the minimum width have to be reached at the same location in the smoke plume. The same applies to the maximum detection speed and maximum width. It is not sufficient to measure one value at the bottom and the other value at the top of the smoke plume (see chapter Technical data).

Direction and angle of a smoke plume

The inclination angle and direction of a smoke plume are important indicators to detect smoke. In the field of view of the camera, moving smoke plumes can have a maximum tilt angle of 90° and will be detected.

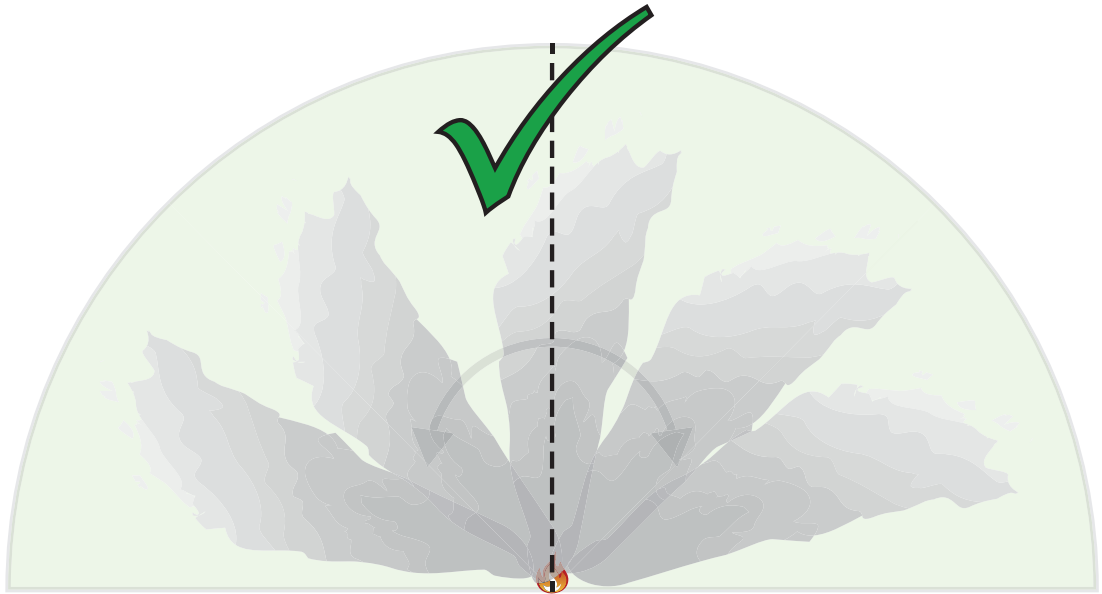

Smoke plumes must move in a constant direction with a minimum density to be detected by the video-based fire detection. Irregular expanding smoke and smoke plumes moving in the direction of the camera might not be detected.

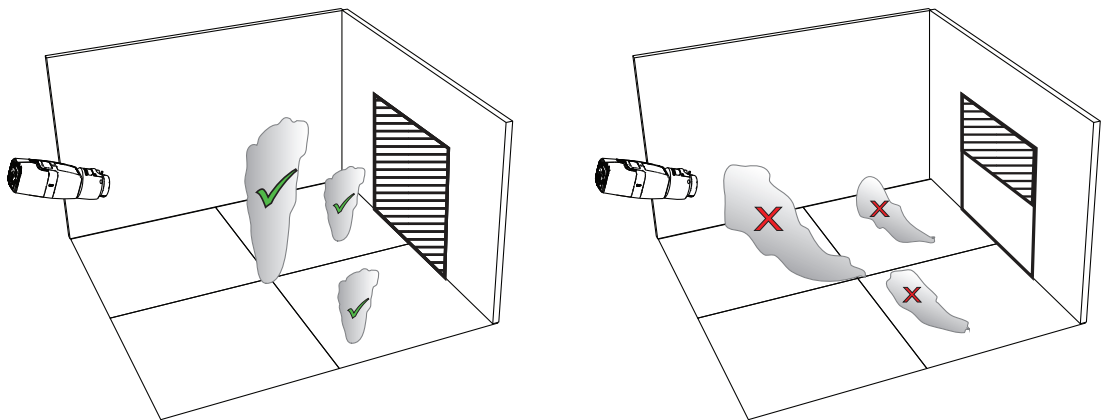

The intelligent smoke detection covers a large area of application. Nevertheless, there might be some disruptive factors in the operational environment of the customer. Objects with a similar movement pattern of smoke might cause false alarms, e.g. escalators or conveyor belts.

Smoke density

A minimum smoke density is required to identify the smoke plume.

The smoke density is described as the decrease of a local image contrast with the presence of smoke as seen in the following graphic:

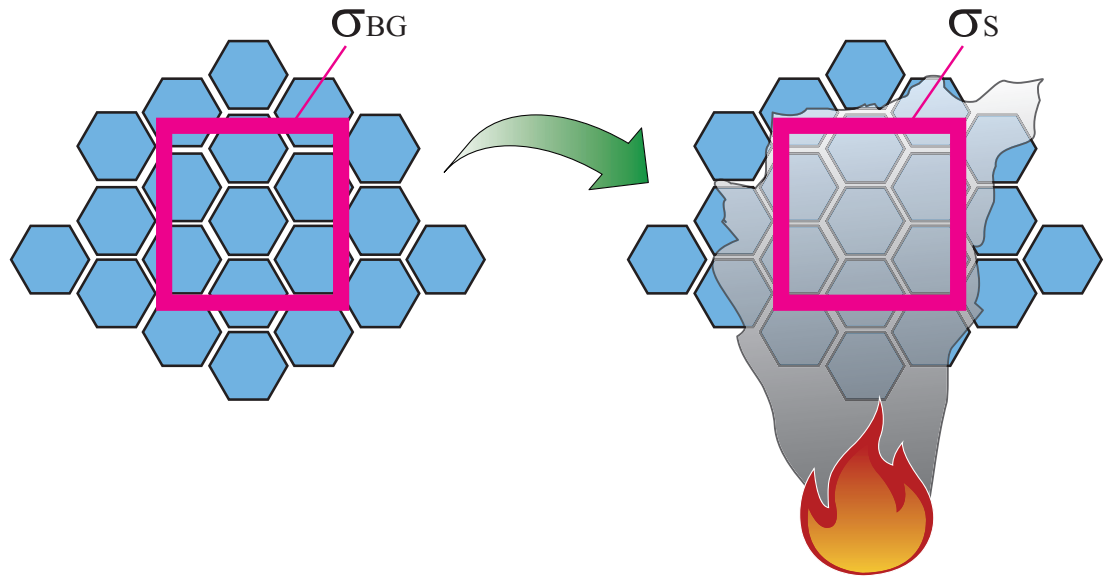

Figure 3.1: Smoke density definition

The effect of contrast reduction by smoke is described by the formula

$$d = \left(1 - \frac{\sigma_S}{\sigma_{BG}}\right) * 100\%$$

with the contrast values for a temporal average image with smoke σ_s and the contrast for the background σ_{bg} .

Exemplary images for smoke densities are shown in the following table:

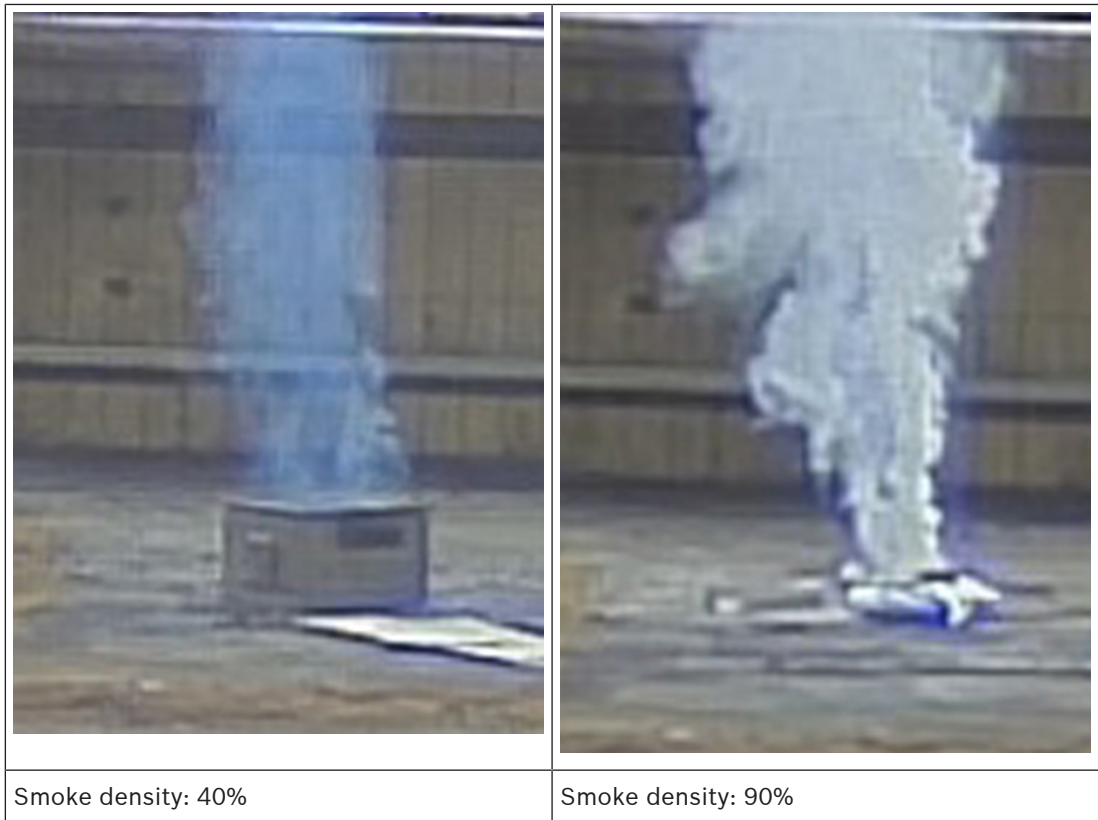

In regular conditions with an equal colored background, smoke is visible when the smoke density exceeds 40%.

In case of a background with high color saturation (e.g. deep blue) or a high background intensity or strong contrasts or very strong color contrast (e.g. black and white or blue and yellow) behind the smoke region the required smoke density can increase up to 90% before smoke is detected.

**Notice!**

All smoke detection properties are influenced by wind. For more details, see the Planning Manual.

4 Planning

A fire safety analysis should be performed to determine the characteristics of the area including a fire load calculation. The placement of the camera or cameras results from the application environment of the customer.

4.1 Application basics of video-based fire detection

4.1.1 Protection objective - Area monitoring

Here the focus is on monitoring an entire indoor and outdoor area. In most cases several cameras are necessary to monitor the area.

4.1.2 Protection objective - Area-Of-Interest

Only a certain area shall be monitored separately (e.g. a machine/dedicated storage area in a big storage area).

4.2 Flame/smoke sizes (50/75 cm)

These sizes are proposed because they are based on the fire sizes of standard test fires from EN 54 or ISO 7240 and thus offer comparability with standard fire detection technologies. EN 54/ISO 7240 are only applicable for indoor areas. For outdoor areas see chapter Minimum distances.

Refer to

– *Minimum distances, page 26*

4.3 Check list

It is recommended to determine the following parameters of the environment and include them in the planning.

1. What is required?

Floor plan available? Yes No

2. What should be monitored? (Inspection may be required)

Type of monitoring: Area monitoring Area-of-Interest

Detectable flame and smoke sizes:

Standard fire (50 cm flame/75 cm smoke) Other requirements:

3. Illumination situation

Available illumination: Natural light Artificial light Non-visible illumination (IR)

Illuminance levels: ____ lx At least 2 lx without IR Dynamics in the application

Potential backlight: Position, window facade, influence of the sun, see chapter *Influencing factors* [Important, in order not to exceed the dynamic factor, do not align the camera position against windows or direct sunlight.]

*at the installation
site (outdoor),
page 24*

Lighting dynamics: Max. lx _____ Min. lx _____ [Max. factor ≤ 5
between max. and
min.]

Possible camera positions: To be specified in the plan Specified by the customer Freely definable

4. Mounting height

Given height: _____ m Freely definable

[The height should be chosen so that the camera is mounted relatively flat and there are no obstacles in the field of view of the camera.]

5. Miscellaneous

Environmental influences: Dust Humidity Low temperature (below -10°C)

[Housing required]

Wiring: IP wiring Planning the wiring

Power supply: POE 12 VDC
 230 VAC with housing 24 VAC with housing POE + housing

Emergency power supply necessary for.. Network components Cameras Illumination

6. Redundancies

Redundant lighting Necessary Not necessary

Power supply lighting Necessary Not necessary

Power supply camera Necessary Not necessary

Power supply for network components Necessary Not necessary

7. Alerting

Alarm transmission to:

- Fire alarm control panel with relay (Attention: not according to EN54!)
- Local Monitoring center for verification (via video management system)
- External Monitoring center for verification (via video link)

You can also use the free planning tool (VFD Planning help) in the video-based fire detection download area, available at www.boschsecurity.com.

4.4 Influencing factors at the installation site (indoor)

You can influence some factors that might disturb the video-based fire detection algorithm. If you consider these conditions during the planning phase, you will minimize the probability of false alarms. The following information is very important to achieve an environment optimized for better and faster detection. Choose carefully the position of the camera by considering the following values:

Influencing factor	Countermeasure	Information
ILLUMINATION	Take care of a well illuminated environment. Use a luxmeter to determine the illumination values (see <i>Illumination, page 10</i>).	A well and evenly illuminated environment is important to achieve better image quality and therefore a better base for analyzing the video image.
DYNAMIC RANGE	The dynamic range in the detection area must be equal or less than factor 5. Use a luxmeter to determine the illumination values. These values have to be collected successively in the same scene.	The dynamic range represents the ratio between the minimum and maximum brightness in the environment.
BACKLIGHT	Avoid backlights in the video image by: <ul style="list-style-type: none"> - Changing the camera position and monitor in another direction. - Changing the horizontal and/or vertical tilt angle. - Excluding windows and roof lights from the field of view of the camera. 	Backlights create bright areas in the video image and can lead to false alarms. Due to the high dynamic range resulting from the backlight, fires may not be detected.

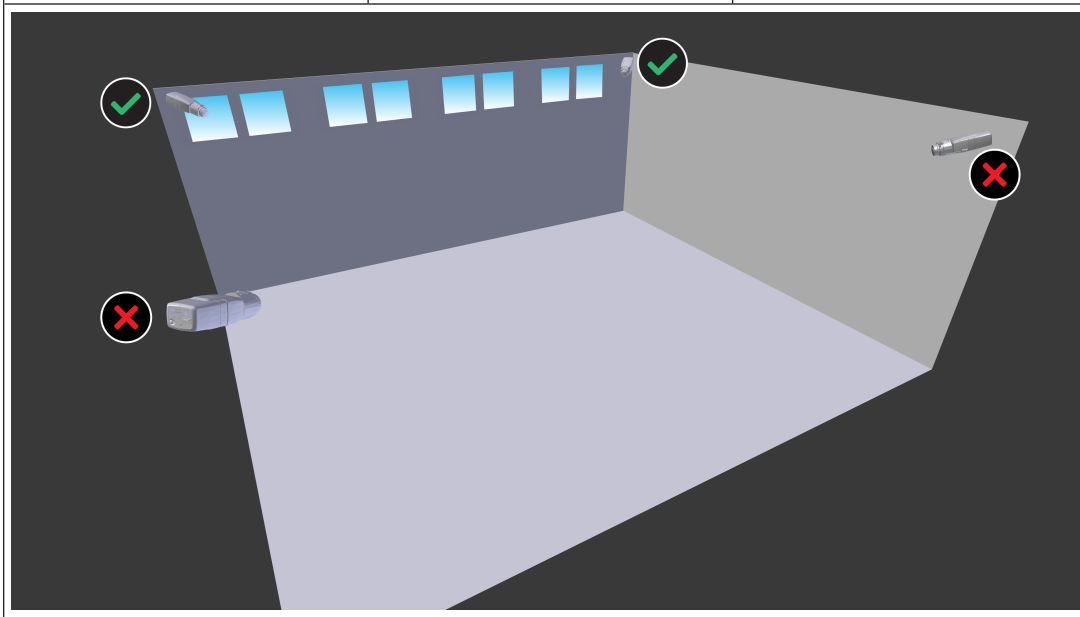

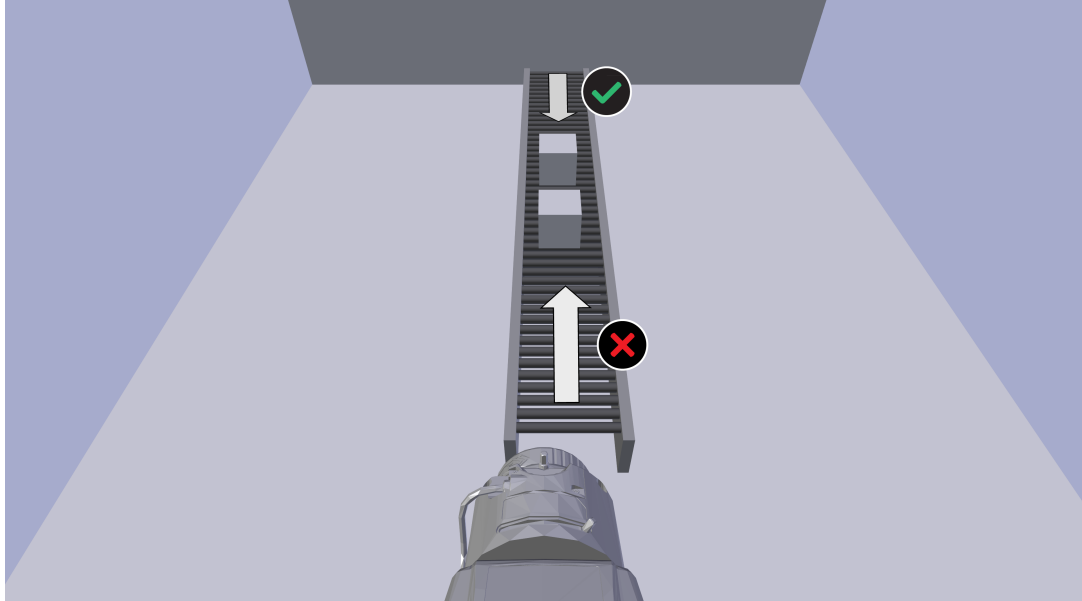
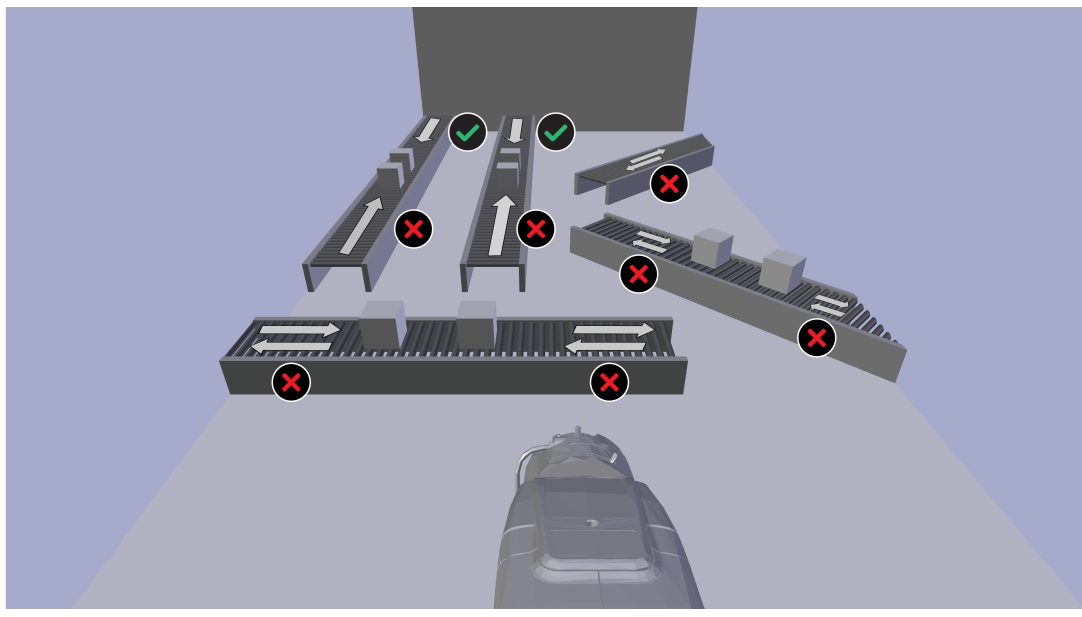
Influencing factor	Countermeasure	Information
<p>CONVEYOR BELTS</p>	<p>Choose a mounting position where conveyor belts are moving downwards in the picture. Exclude oblique and sideways movements in the video scene.</p>	<p>Conveyor belts moving in another direction than downwards in the picture area might be identified as smoke.</p>
		
		
<p>FANS</p>	<p>Avoid rotating fans in the field of view of the camera. Alternatively use masking</p>	<p>The visible rotating fan of a ventilation system may disturb the algorithm and could result in false alarms.</p>

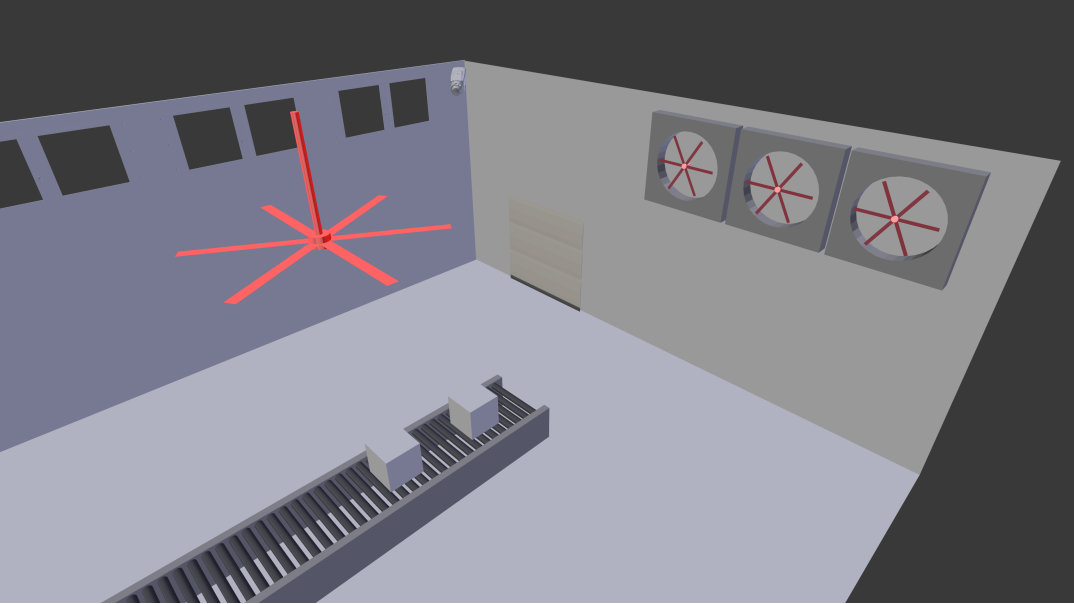
Influencing factor	Countermeasure	Information
	<p>(see Adjustments of image regions) in the configuration menu of the camera.</p> <p>If rotating fans can't be avoided in the scene, set Sensitivity to low to suppress false alarms (see General settings).</p>	
		
<p>BLINKING LIGHTS</p>	<p>Check for blinking lights in your application. Use masking to exclude blinking lights from the detection or increase the verification time (see Adjustments of image regions).</p> <p>If blinking lights cause false alarms, set Sensitivity to low (see chapter General settings).</p>	<p>Blinking lights in the detection area may disturb the algorithm and lead to false alarms.</p>

Influencing factor	Countermeasure	Information
		
LARGE / SLOW MOVING OBJECTS (e.g. cranes, large vehicles)	Avoid permanently installed and slow moving objects in the field of view of the camera. If large / slow moving objects are moving continuously in the same direction, mount the camera with view against the motion direction of the objects (like conveyor belts). In case of false alarms, set Sensitivity to low (see chapter General settings).	Large, slow moving objects behind other objects may have an appearance similar to fire or smoke and lead to false alarms.
VIBRATIONS	Only mount the camera in vibration isolated areas.	Vibrations can move and shake the camera and result in false alarms.

4.5 Influencing factors at the installation site (outdoor)

Influencing factor	Countermeasure	Information
WIND	Use larger opening angles.	With larger opening angles the smoke appears slower in the image. Notice: Changing the opening angle has an influence on smoke size and minimum distance. Refer to <i>Minimum distances</i> , page 26.

Influencing factor	Countermeasure	Information
	Plan with larger flame sizes.	Flames might be pushed downwards by wind and appear smaller in the camera picture. Larger flames must be considered in the planning.
	2 nd camera positioned from a different viewing angle.	Wind can move smoke towards the camera. This leads to a downward movement of smoke in the image. Smoke is not detected (downwards rising smoke is not detected by the algorithm).
	-	Rotating/turning smoke: <ul style="list-style-type: none"> - No constant moving direction - No detection possibility if there is no constant direction during the whole verification time
ILLUMINATION	Position and align the camera depending on the course of the sun. Use shadow areas.	Notice: If the background is too bright, flames might not be detected. Sun illuminated background may have the same color as flame color. Flames cannot be visible in front of such a background (see chapter <i>Illumination and brightness</i> , page 31).
SKY / CLOUDS in the field of view	Positioning the camera preferably high: <ul style="list-style-type: none"> - Tilt camera more towards the ground. - No sky in the field of view. 	Clouds: <ul style="list-style-type: none"> - May have similar behavior like smoke. - May trigger false alarms. Sky: <ul style="list-style-type: none"> - Very bright, backlight, dynamic factor in field of view - Possibility of non-detections

Refer to

- *Minimum distances*, page 26
- *Illumination and brightness*, page 31

4.6 Minimum distances

4.6.1 Indoor

The camera must be mounted according to the following graphic:

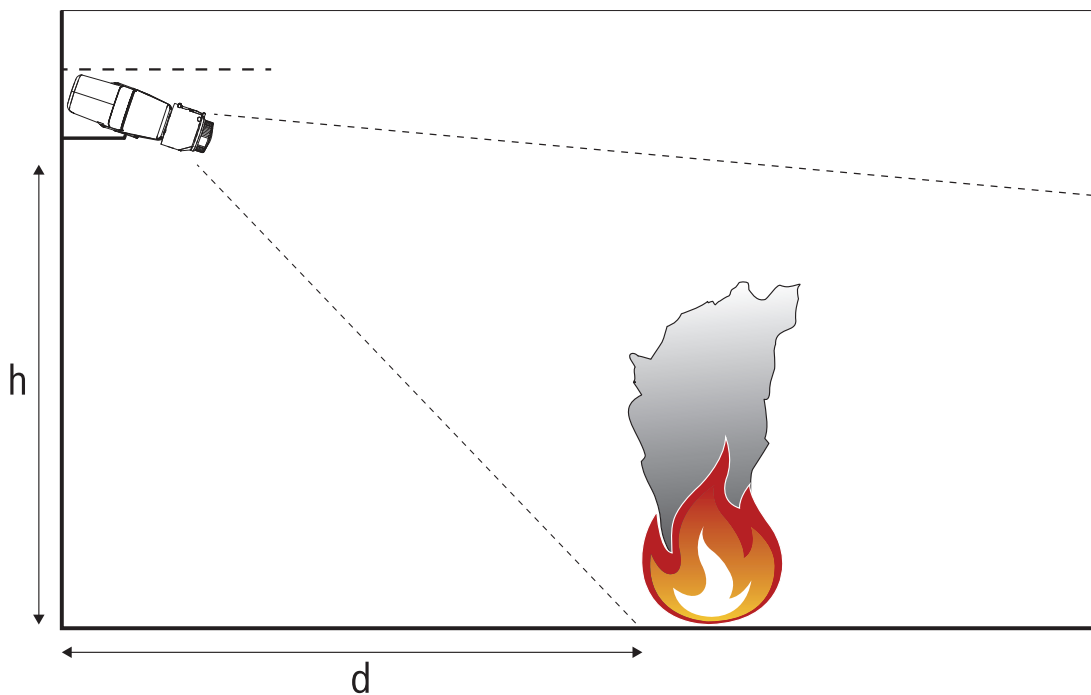

d	Minimum distance to fire
h	Installation height

The table below demonstrate exemplarily the minimum distances to fire or smoke depending on the installation height:

Installation height [m]	Minimum distance to fire [m]
2.5	3.3
3	4.0
3.5	4.6
4	5.3
4.5	6.0
5	6.6
5.5	7.3
6	8.0
6.5	8.6
7	9.3
7.5	10.0
8	10.6

8.5	11.3
9	11.9
9.5	12.6
10	13.3

Table 4.1: Minimum distance to fire

4.6.2

Outdoor

Minimum distance to fire (m) depending on different wind speeds

The following tables provide information about the minimum distances to fire (m) depending on different wind speeds.



Notice!

The minimum detection distance also depends on installation height (see chapter *Minimum distances, page 26*), tilt angle of the camera and opening angle of the lens.

The calculated distances refer to the same wind speeds in all tables. Since the minimum detection values are related to this, the following detection values apply to the distance specifications given below:

Wind speed			Detection Sizes [m]	
m/s	km/h	Beaufort	Flame	Smoke
1	4	1	0.11	0.16
7	25	4	0.82	1.19
19	69	8	2.32	3.37
33	119	12	4.03	5.87

LVF-5005C-S4109 (standard lens)

Wind speed	Minimum distance [m]		
m/s	100°	60°	45°
1	4.2	8.7	12.1
7	31.2	64.5	89.9
19	88.3	182.3	254.2
33	153.8	317.5	442.6

LVF-8008C-P0413

Wind speed	Minimum distance [m]		
m/s	100°	60°	33°
1	4.2	8.7	16.9
7	31.2	64.5	125.7
19	88.3	182.3	355.4
33	153.8	317.5	618.9

Refer to

– *Minimum distances, page 26*

4.7**Maximum distances****4.7.1****Indoor**

The tables below demonstrate exemplarily the maximum distances to a fire depending on fire size and opening angle of the camera lens:

Maximum distance to fire in m (Flame detection)

LVF-5005C-S4109 (standard lens)			
			Opening angle [°]
	100	60	45
Fire width [m]			
0.3	18.2	27.6	36
0.5	30.4	46.1	60
1	60.9	92.2	120
2	121.9	184.4	240.1

LVF-8008C-P0413			
			Opening angle [°]
	100	60	33
Fire width [m]			
0.3	18.4	27.6	48.4
0.5	30.7	46	80.7
1	61.5	92.1	161.4
2	123.1	184.3	322.8

Maximum distance to fire in m (Smoke detection)

LVF-5005C-S4109 (standard lens)			
			Opening angle [°]
	100	60	45
Smoke width [m]			
0.3	12.5	19.3	25.2
0.5	21.3	32.2	42
1	42.6	64.5	84

LVF-5005C-S4109 (standard lens)			
2	85.3	129	168.1

LVF-8008C-P0413			
Opening angle [°]			
	100	60	33
Smoke width [m]			
0.3	12.9	19.3	33.8
0.5	21.5	32.2	56.4
1	43.1	64.5	112.9
2	86.2	129	225.9

Maximum distances

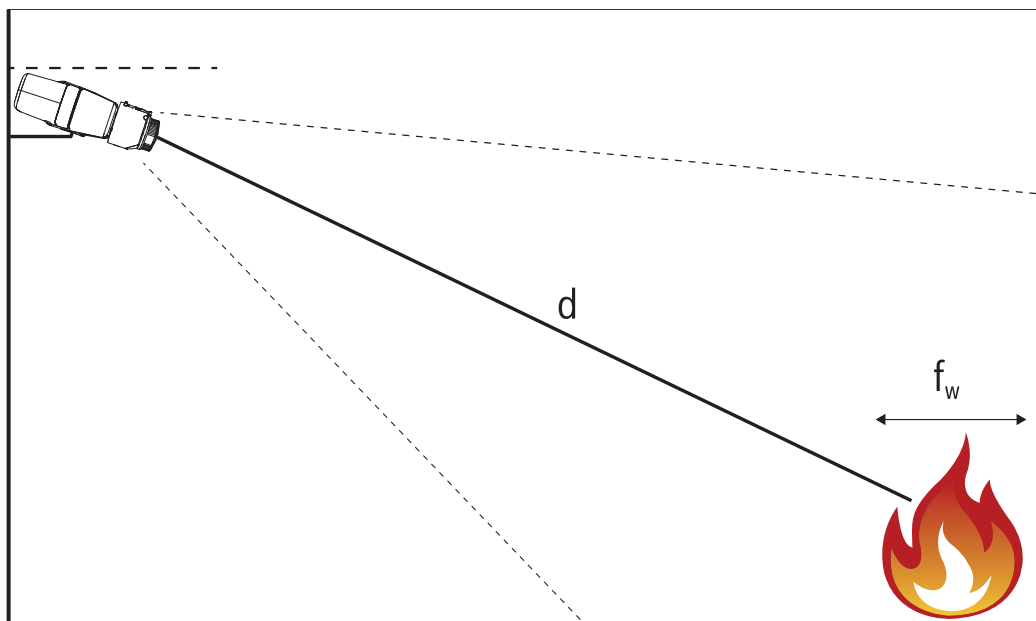

d	Maximum distance to fire
f _w	Fire width

4.7.2

Outdoor

The maximum distance is either given by the customer defined maximum flame and smoke size or by the minimum smoke speed (see *Minimum distances, page 26*).

Refer to

- *Technical data, page 41*
- *Technical data, page 41*
- *Minimum distances, page 26*

4.8 Image margin area

The following table shows exemplarily the deviation in percent from the maximum detection distances at the middle of the picture:

Due to the optical distorsion of the lens, there are deviating maximum detection distances at the margin area of the picture.

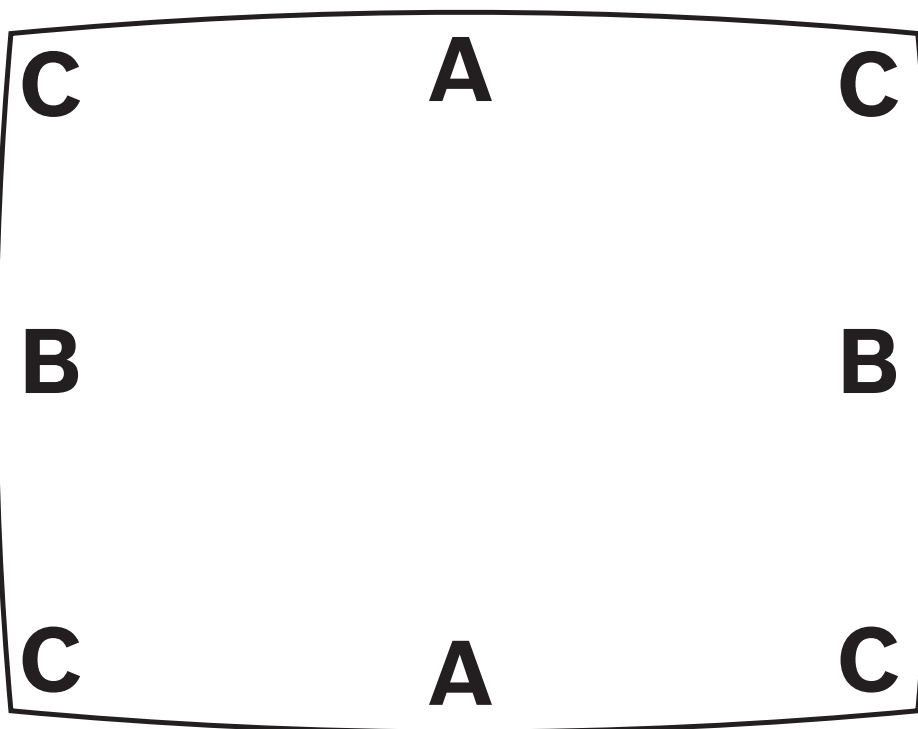

Figure 4.1: Definition of margin areas of the picture

A	Horizontal margin area
B	Vertical margin area
C	Corner area

LVF-5005C-S4109 (standard lens)

	Margin area		
	A	B	C

Opening angle of the lens			
100°	13	40	51
90°	11	33	40
60°	7	23	30
45°	5	15	20

LVF-8008C-P0413

	Margin area		
	A	B	C
Opening angle of the lens			
100°	15	42	55
90°	12	34	46
60°	5	15	21
45°	3	10	12

4.9 Immediate environment of the camera

4.9.1 Illumination and brightness

Backlight should be avoided. The visibility of a smoke plume or flames decreases rapidly with increasing backlight. Try to minimize the amount of very bright background lights in your specific environment as far as it is meaningful and possible.

AVIOTEC IP starlight 8000 needs a minimum illumination of 2 lx. Generally, a uniformly illuminated monitoring area with a dynamic range in the camera image equal or less than factor 5 is advantageous.

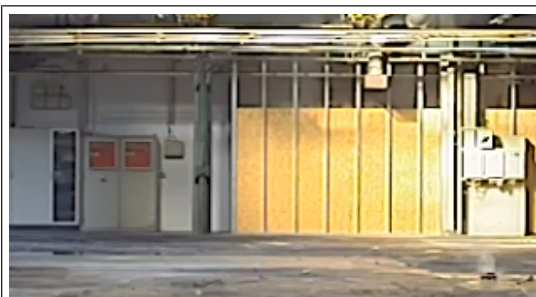

Smoke plume and backlight



Smoke plume without backlight



4.9.2 Infrared (IR) illumination



Notice!

When using infrared light, it is necessary to set the **Day/Night** mode in the camera menu to **Monochrome** or **Auto**.



Notice!

If you use infrared light in poor lighting situations and different lighting situations arise in your application, the fire detection must be tested again in each lightning situation!

Generally, a uniformly infrared illuminated monitoring area with a dynamic range in the camera image equal or less than factor 5 is advantageous.

Infrared backlight is to be avoided. The visibility of a smoke plume or flames decreases rapidly with increasing Infrared backlight. Try to minimize the amount of very bright background lights in your specific environment as far as it is meaningful and possible.

4.9.3 Privacy protection







Notice!

There is no fire detection in privacy defined masks created in the Intelligent Video Analytics.

To protect privacy, individual masks on the video screen can be defined to cover up areas in which privacy has to be guaranteed. Privacy defined masks remain stored after a reset of the camera, even after upgrading to a new firmware.

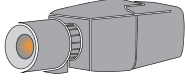
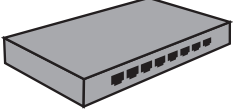
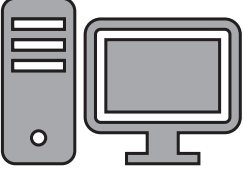
5 Camera integration

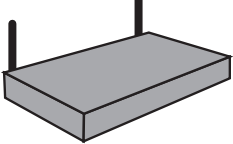
The video-based fire detection can be easily integrated into the network environment of the customer. There are several possibilities to connect the camera. Various combinations are possible. The individual customer network properties determine the performance and scalability of the system.

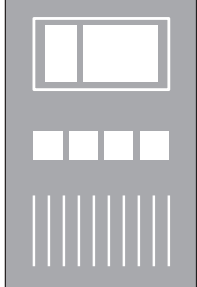
	<p>Camera</p>
	<p>Network switch, PoE-ready</p>
	<p>Client PC</p>
	<p>Video Recording Manager (VRM)</p>
	<p>Router</p>
	<p>Internet</p>
	<p>Monitoring Center</p>
	<p>Fire alarm control panel</p>

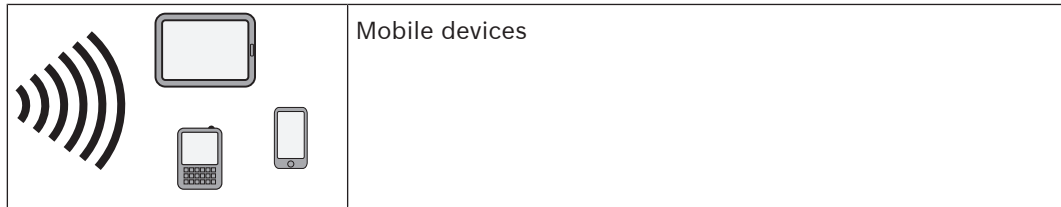

5.1 Local Area Network

Due to the IP-based camera, the integration of the video-based fire detection into the network of the customer is easy. There are a lot of opportunities regarding to scalability and enlargement of the network.

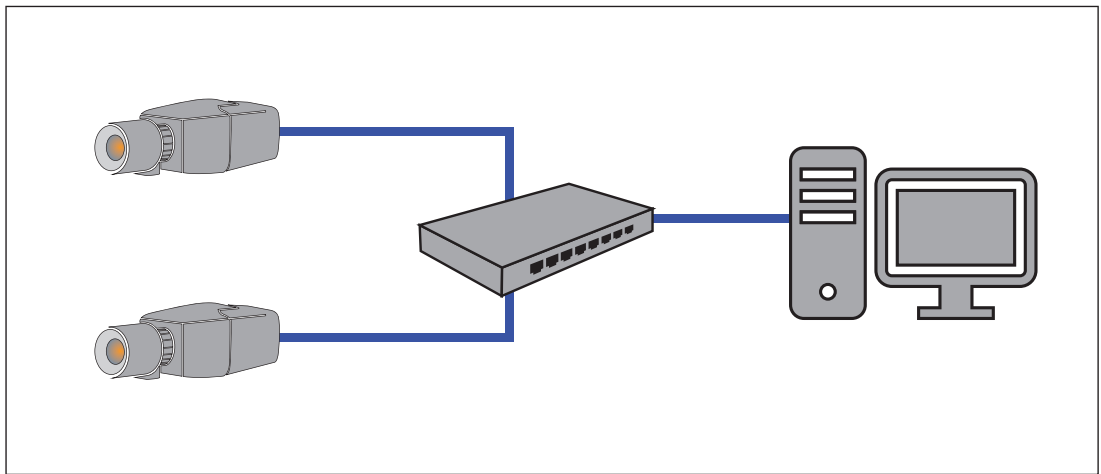

5.2 Local Area Network with recording solution

Recording and archiving functionality in the network can be realized by a video recording manager (VRM). Fire cause analysis and traceability due to legal matters are only two examples of a recording solution.

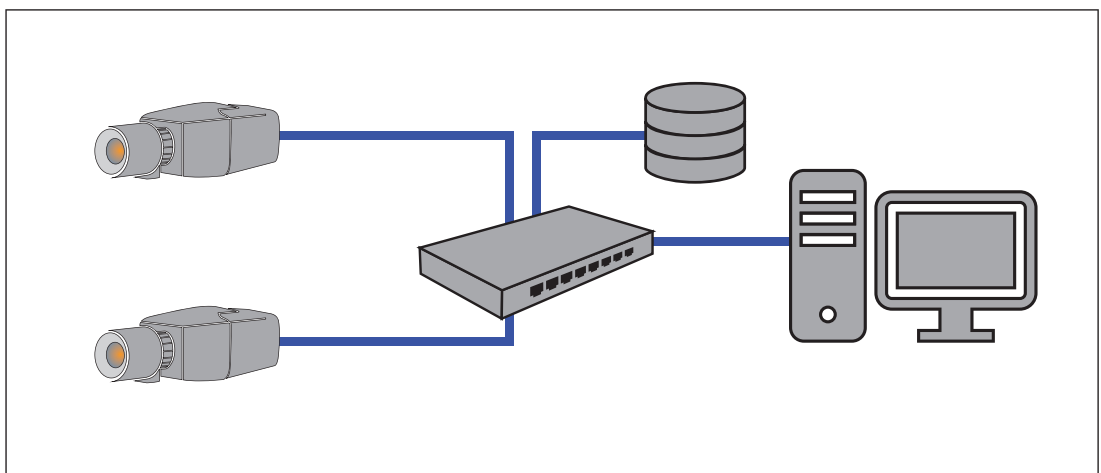

5.3 Monitoring Center

In a monitoring center, alarms can be verified to call the fire brigade and to take care of additional rescue measures.

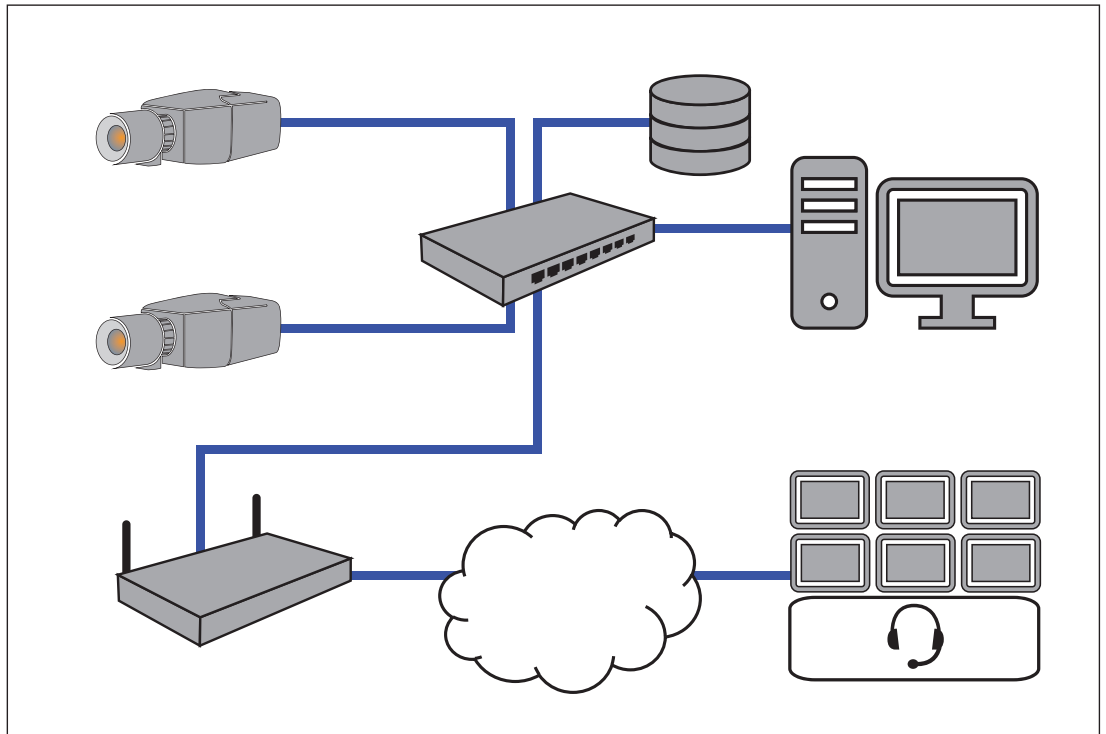

5.4 Fire Alarm Control Panel



AVIOTEC IP starlight 8000 can be connected to the a fire alarm control panel. The alarm will be triggered by the relay output of the camera.



Notice!

No direct connection to fire services in EN54 compliant installations. Authorities can allow a connection to fire services after verifying alarms in a monitoring center.

Connection to a fire alarm control panel

The alarm output of the camera can be connected to a fire alarm control panel.

The camera alarm output is triggered by a relay that is normally open. In case of alarm the relay is closed.

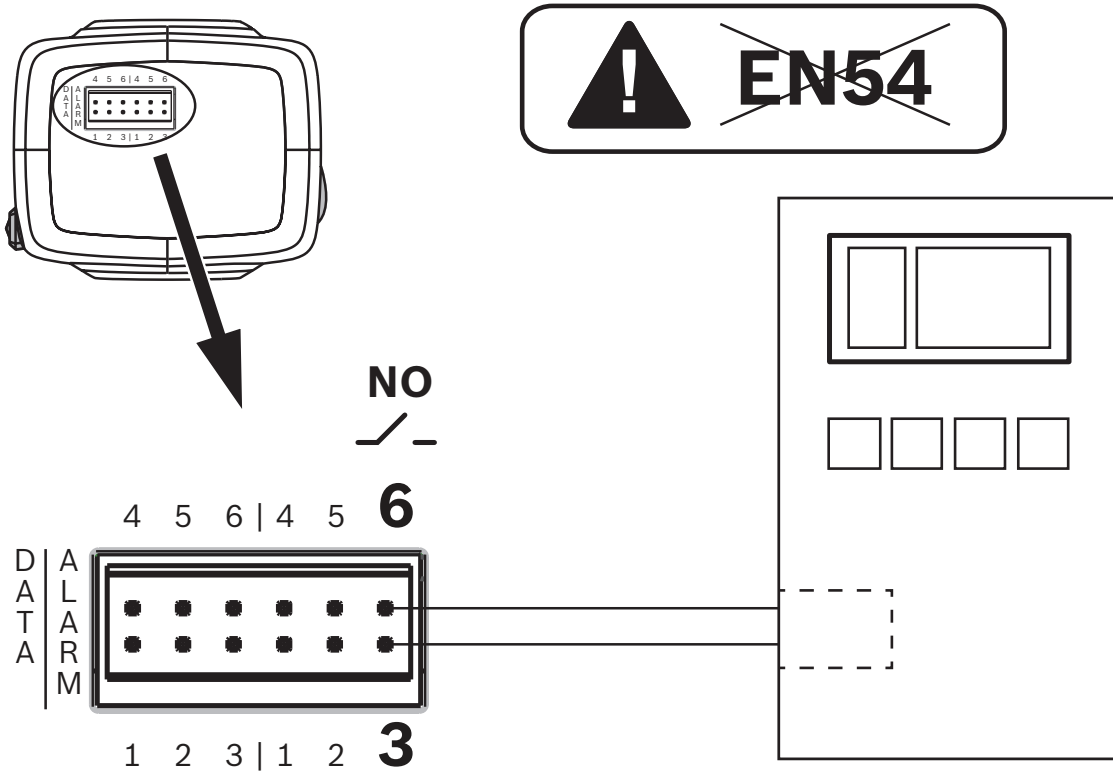

See the documentation of the individual manufacturer for further information about the connection to a fire alarm control panel.

5.5

Mobile Devices

Another advantage of the network integration of the video-based fire detection is the expandability to mobile devices, such as tablets or smartphones.

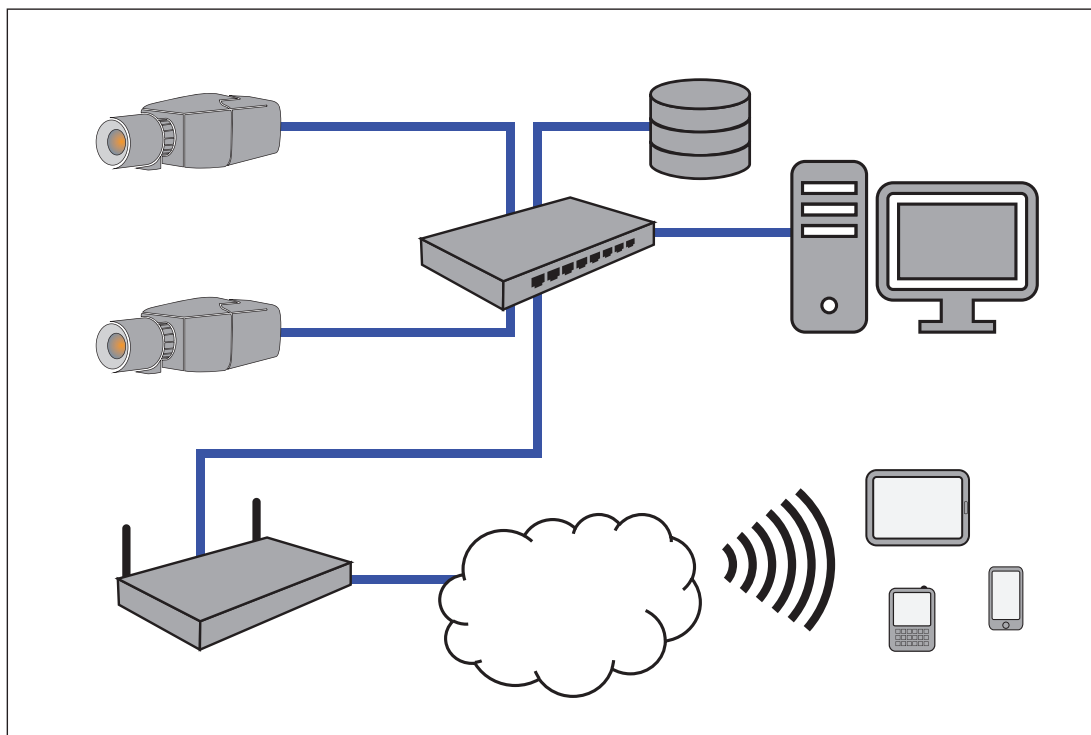

6 Use cases

Fire detection in combination with VCA functionality offers different use cases. These four use cases are described below.

6.1 Fire detection only

This is the standard setting of the camera. You can choose this standard option if different fire detection profiles and profile scheduling are not necessary for your application. In case you need to adapt the general fire detection settings, please refer to chapter Adjustment of detection settings.

6.2 Fire detection and VCA profiles

If you want to use fire detection and video surveillance functions, e.g. detect unauthorized access, you can create two individual VCA profiles. Please be aware that only **one** VCA profile can be active at a time. The fire detection profile depends on the corresponding VCA profile and these are always active simultaneously. For example if you choose VCA profile (Fire #1), the Fire detection profile (Fire #1) is enabled. If you choose VCA profile (Fire #2), the Fire detection profile (Fire #2) is enabled.

	Silent VCA (VCA not configurable)	VCA profile (Fire #1)	VCA profile (Fire #2)
Fire detection (Silent VCA)	linked (see <i>Fire detection only, page 38</i>)	x	x
Fire detection (Fire #1)	x	linked	x
Fire detection (Fire #2)	x	x	linked

How to change the VCA profiles:

1. Go to **Configuration > Alarm > VCA** .
2. In **VCA configuration** choose the corresponding profile.
3. Set up and modify the VCA profile (refer to the IVA documentation for more information and IVA settings).
4. Go to **Configuration > Alarm > Fire detection**.
5. Set up the corresponding fire detection profile (see *Fire detection only, page 38*).

6.3 Scheduled fire detection

In many industrial applications you have a lot of movement during the day and very little movement at night. A scheduled configuration allows you to link a VCA profile with the days and times at which the video content analysis is to be active. Schedules can be defined for weekdays and for holidays.

1. Go to **Configuration > Alarm > VCA** .

2. In the **VCA configuration** drop-down list, select **Scheduled**.

Link any number of 15-minute intervals with the VCA profiles for each day of the week. Moving the mouse cursor over the table displays the time below it. This aids orientation.

1. Click the profile to link in the **Time periods** field.
2. Click in a field in the table, hold down the mouse button and drag the cursor over all the periods to be assigned to the selected profile.
3. Use the right mouse button to deselect any of the intervals.
4. Click **Select All** to link all time intervals to the selected profile.
5. Click **Clear All** to deselect all of the intervals.
6. When finished, click **Set** to save the settings in the device.

Define holidays on which a profile should be active that are different to the standard weekly schedule.

1. Click the **Holidays** tab. Any days that have already been selected are shown in the table.
2. Click **Add**. A new window opens.
3. Select the desired date from the calendar. Select several consecutive calendar days by holding down the mouse button. These will later be displayed as a single entry in the table.
4. Click **OK** to accept the selection. The window closes.
5. Assign the individual holidays to the VCA profiles, as described above.

Deleting Holidays

Delete defined holidays at any time:

1. Click **Delete**. A new window opens.
2. Click the date to delete.
3. Click **OK**. The item is deleted from the table and the window closes.
4. The process must be repeated for deleting additional days.



Notice!

If you have not yet created any fire detection profiles (see *Fire detection and VCA profiles, page 38*), you must do so and go to **Configuration > Alarm > Fire detection**.

Refer to

- *Fire detection and VCA profiles, page 38*

6.4

External trigger to switch fire detection mode

This configuration allows you to change the VCA profile / fire detection profile when triggered by an event.

- ▶ In the **VCA configuration** drop-down list, select **Event triggered**.

The camera offers two alarm inputs (see chapter Alarm input).

1. In **Configuration** select **Trigger**.
2. Select a physical alarm (alarm input) as a trigger, choose **Alarm input 1** or **Alarm input 2**.
3. In **Trigger active** select the VCA configuration that is to be enabled via an active trigger. A green check mark to the right of the list field indicates that the trigger is active.
4. In **Trigger inactive** select the VCA configuration that is to be activated if the trigger is not active. A green check mark to the right of the list field indicates that the trigger is inactive.

Delay [s]

Select the delay period for the reaction of the video content analysis to trigger signals. The alarm is only triggered after a set time interval in seconds has elapsed and then only if the triggering condition still exists. If the original condition has been restored before this time interval elapses, the alarm is not triggered. A delay period may be useful in avoiding false alarms or frequent triggering. During the delay period, the **Silent VCA** configuration is always enabled.

- ▶ Go to **Interfaces**, select **Alarm Inputs** and adapt the corresponding alarm input to your needs.

**Notice!**

If you have not yet created any fire detection profiles (see *Fire detection and VCA profiles*, page 38), you must do so and go to **Configuration > Alarm > Fire detection**.

One example would be an environment with cleaning cycles. A key switch can be used as an external trigger to switch between the different fire detection profiles.

7 Technical data

Algorithm Overview	
Min. detection size for Smoke, standard setting (% of picture width)	1.6
Smoke speed (% of picture height /s)	0.7 - 16
Min. Smoke density (%)	40
Min. detection size for Flame, standard setting (% of picture width)	1.1
Min. illumination level (lx)	2
Min. illumination level with IR illumination (lx)	0

Environmental	
Operating Temperature	-20°C to +50°C (-4°F to 122°F)
Storage Temperature	-30°C to +70°C (-22°F to +158°F)
Operating Humidity	20% to 93% RH
Storage Humidity	up to 98% RH

Input/output	
Analog video out	SMB connector, CVBS (PAL/NTSC), 1 Vpp, 75 Ohm
Audio line in	1 Vrms max, 18 kOhm typical,
Audio line out	0.85 Vrms at 1.5 kOhm typical,
Audio connectors	3.5 mm mono jack
Alarm input	2 inputs
Alarm input activation	+5 VDC nominal; +40 VDC max. (DC-coupled with 50 kOhm pull-up resistor to +3.3 VDC) (< 0.5 V is low; > 1.4 V is high)
Alarm output	1 output
Alarm output voltage	30 VAC or +40 VDC max. Maximum 0.5 A continuous, 10VA (resistive load only)
Ethernet	RJ45
Data port	RS-232/422/485

Local storage	
Internal RAM	10 s pre-alarm recording
Memory card slot	Supports up to 32 GB microSDHC / 2 TB microSDXC card. (An SD card of Class 6 or higher is recommended for HD recording)

Local storage	
Recording	Continuous recording, ring recording, alarm/events/schedule recording
Mechanical	
Dimensions (W x H x L)	78 x 66 x 140 mm (3.07 x 2.6 x 5.52 inch) without lens
Weight	855 g (1.88 lb) without lens
Color	RAL 9006 Metallic Titanium
Tripod Mount	Bottom and top 1/4-inch 20 UNC
Sustainability	PVC free
Network	
Protocols	IPv4, IPv6, UDP, TCP, HTTP, HTTPS, RTP/RTCP, IGMP V2/V3, ICMP, ICMPv6, RTSP, FTP, ARP, DHCP, APIPA (Auto-IP, link local address), NTP (SNTP), SNMP (V1, V3, MIB-II), 802.1x, DNS, DNSv6, DDNS (DynDNS.org, selfHOST.de, no-ip.com), SMTP, iSCSI, UPnP (SSDP), DiffServ (QoS), LLDP, SOAP, CHAP, digest authentication
Encryption	TLS1.0/1.2, AES128, AES256
Ethernet	10/100 Base-T, auto-sensing, half/full duplex
Connectivity	Auto-MDIX
Interoperability	ONVIF Profile S; ONVIF Profile G

8 Troubleshooting

The following issues can be solved in the detection settings (**Configuration > Alarm > Fire detection**).

8.1 False Alarms

8.1.1 Quick solution to solve false alarms

A fast way to identify and solve region-stable false alarms in the camera image is automasking. The system automatically generates predefined masks from the alarm memory.

Navigate to **Configuration > Alarm > Fire detection**.

2. Select **Automask**.
3. Select **Set** to confirm the changes.

8.1.2 False alarms under 4 seconds concerning the whole detection area

In this case the general settings of the fire detection have to be adjusted.

Problem	Solution
Short false alarms for smoke detection.	Increase the duration of smoke detection. (Smoke > Verification time [s])
Short false alarms for flame detection.	Increase the duration of flame detection. (Flames > Verification time [s])

8.1.3 False alarms at small constant areas

Individual image areas are affected and have to be adjusted.

Problem	Solution
Objects cause flickering motion, e.g. shadow of a flag in the wind.	Mask out the disturbing image area (for flame). <i>Flame detection will be deactivated in this mask.</i>
Continuous motion in the picture causes false alarms, e.g. escalators.	Mask out the disturbing image area (for smoke). <i>Smoke detection will be deactivated in this mask.</i>
Temporary motion causes false alarms, e.g. roller shutter.	Mask out the disturbing image area (). <i>Smoke detection will be delayed in this mask.</i>

8.1.4 Vibrations at the camera site

Problem	Solution
Vibrations are transferred to the camera.	Avoid vibrations at the camera site.

Camera picture is trembling.	Make sure the camera is firmly mounted.
The camera position changed because of vibrations.	Move the camera to its initial position and check the field of view. Make sure the camera is firmly mounted.

8.2 No alarm transmission

Problem: Alarms are visible in the web browser but there is no alarm transmission to the video client.

Solution:

- Check network connection and settings (**Configuration -> Network**)
- Check relay connection and settings (**Alarm > Interfaces > Alarm Outputs**)
- Check fire detection settings (**Configuration > Alarm > Fire detection**)
- Check the video client settings

8.3 No fire detection

- **Problem:** No detection of fire.
- **Solution:**
- Check fire detection settings (**Configuration > Alarm > Fire detection**)
- Check mask settings
- Check privacy mask settings
- Check the focus of the lens (**Configuration -> Camera -> Installer Menu -> Open... ->)**
- Check obstructions in the field of view
- Check the detection area
- Check minimum/maximum distance to fire
- Check the illumination. Different lighting conditions (e.g. sodium light) might require the use of the Expert Mode (not VdS certified).

8.4 Image quality

Interference of the camera image

Small image areas or the whole image area are affected by interferences.

Problem	Solution
Artificial light, e.g. fluorescent light, causes flickering of the camera image.	Go to Installer Menu > ALC mode and change to fluorescent mode.

8.5 Camera

If a fault cannot be resolved, please contact your supplier or system integrator, or go directly to Customer Service.

The version numbers of the internal firmware can be viewed on a service page. Please note this information before contacting Customer Service.

1. In the address bar of your browser, after the unit IP address, enter: /version
for example: 192.168.0.80/version
2. Write down the information or print out the page.

The camera offers a variety of configuration options. Therefore, check that it works properly after installation and configuration. This is the only way to ensure that the camera will function as intended in the event of an alarm.

Your check should include the following functions:

- Can you connect to the camera remotely
- Does the camera transmit all the data required?
- Does the camera respond as desired to alarm events?
- Is it possible to control peripheral devices, if necessary?

The camera has four LEDs on the rear panel:

- Two LEDs indicate the camera status (red for error; green for OK)
- Two LEDs (green and orange) beside the network connection indicate the LAN and PoE status

No OSD messages appear.	Special Video SDK is required. Video management software from third parties does not use the SDK.
-------------------------	---

The ping command can be used to check the connection between two IP addresses. This allows testing whether a device is active in the network.

1. Open the DOS command prompt.
2. Type *ping* followed by the IP address of the device.

If the device is found, the response appears as "Reply from ... ", followed by the number of bytes sent and the transmission time in milliseconds. Otherwise, the device cannot be accessed via the network. This might be because:

- The device is not properly connected to the network. Check the cable connections in this case.
- The device is not correctly integrated into the network. Check the IP address, subnet mask, and gateway address.

9 Appendices

Maximum detection distances for margin areas

Due to the optical distortion of the lens, there are deviating maximum detection distances at the margin area of the picture.

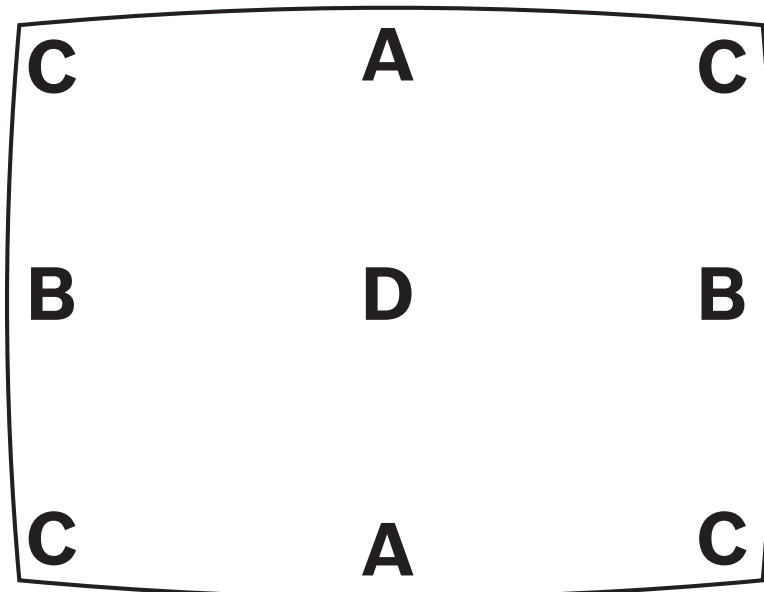

Figure 9.1: Definition of margin areas of the picture

A	Horizontal margin area
B	Vertical margin area
C	Corner area
D	Center

9.1 LVF-5005C-S4109 (standard lens)

9.1.1 Flame detection

Opening angle 100°

Fire width (m)	A	B	C	D
0.3	15.8	10.9	8.8	18.2
0.5	26.5	18.2	14.7	30.4

0.75	39.8	27.3	22.1	45.7
1	53.1	36.5	29.5	60.9
1.25	66.4	45.6	37.0	76.2
1.5	79.7	54.7	44.3	91.4
2	106.3	73.0	59.2	121.9
2.5	132.9	91.3	74.0	152.4
3	159.5	109.6	88.8	182.9

Opening angle 90°

Fire width (m)	A	B	C	D
0.3	17.6	13.2	11.8	19.7
0.5	29.4	22	19.7	32.9
0.75	44	33	29.5	49.3
1	58.8	44.1	39.4	65.8
1.25	73.4	55.1	49.2	82.2
1.5	88.2	66.1	59.1	98.7
2	117.6	88.2	78.8	131.6
2.5	147	110.3	98.5	164.5
3	176.4	132.3	118.3	197.4

Opening angle 75°

Fire width (m)	A	B	C	D
0.3	21.2	17.4	16.0	22.8
0.5	35.4	29.1	26.7	38.0
0.75	53.1	43.7	40.1	57.0
1	70.8	58.2	53.5	76.0
1.25	88.5	72.8	66.8	95.0
1.5	106.2	87.4	80.2	114.0
2	141.6	116.5	107.0	152.0
2.5	177.1	145.7	133.8	190.1
3	212.5	174.9	160.6	228.1

Opening angle 60°

Fire width (m)	A	B	C	D
0.3	26.1	23.4	21.9	27.6
0.5	43.6	39.1	36.6	46.1

0.75	65.4	58.6	54.9	69.1
1	87.3	78.2	73.3	92.2
1.25	109.1	97.7	91.6	115.2
1.5	131.0	117.3	110.0	138.3
2	174.7	156.4	146.7	184.4
2.5	218.3	195.5	183.4	230.5
3	262.0	234.6	220.1	276.6

Opening angle 45°

Fire width (m)	A	B	C	D
0.3	35.0	32.8	32.1	36.0
0.5	58.3	54.8	53.6	60.0
0.75	87.5	82.2	80.4	90.0
1	116.7	109.6	107.2	120.0
1.25	145.9	137.0	134.0	150.0
1.5	175.2	164.5	160.9	180.1
2	233.6	219.3	214.6	240.1
2.5	292.0	274.2	268.2	300.1
3	350.5	329.1	321.9	360.2

9.1.2**Smoke detection****Opening angle 100°**

Fire width (m)	A	B	C	D
0.3	11.1	7.6	6.2	12.8
0.5	18.5	12.7	10.3	21.3
0.75	27.9	19.1	15.5	32.0
1	37.1	25.5	20.6	42.6
1.25	46.4	31.9	25.8	53.3
1.5	55.8	38.3	31.0	64.0
2	74.3	51.1	41.4	85.3
2.5	93.0	63.9	51.8	106.7
3	111.6	76.7	62.1	128.0

Opening angle 90°

Fire width (m)	A	B	C	D
0.3	12.3	9.2	8.2	13.8

0.5	20.5	15.4	13.7	23.0
0.75	30.8	23.1	20.6	34.5
1	41.1	30.8	27.5	46.0
1.25	51.3	38.5	34.4	57.5
1.5	61.6	46.2	41.3	69.0
2	82.3	61.7	55.1	92.1
2.5	102.8	77.1	68.9	115.1
3	123.4	92.6	82.7	138.1

Opening angle 75°

Fire width (m)	A	B	C	D
0.3	14.8	12.1	11.1	15.9
0.5	24.7	20.3	18.7	26.6
0.75	37.1	30.5	28.0	39.9
1	49.5	40.7	37.4	53.2
1.25	61.9	50.9	46.8	66.5
1.5	74.3	61.1	56.1	79.8
2	99.1	81.5	74.9	106.4
2.5	123.9	101.9	93.6	133.0
3	148.7	122.4	112.4	159.7

Opening angle 60°

Fire width (m)	A	B	C	D
0.3	18.2	16.3	15.3	19.3
0.5	30.5	27.3	25.6	32.2
0.75	45.8	41.0	38.5	48.4
1	61.1	54.7	51.3	64.5
1.25	76.3	68.3	64.1	80.6
1.5	91.7	82.1	77.0	96.8
2	122.2	109.4	102.6	129.0
2.5	152.8	136.8	128.3	161.3
3	183.4	164.2	154.0	193.6

Opening angle 45°

Fire width (m)	A	B	C	D
0.3	24.5	23.0	22.5	25.2

0.5	40.8	38.3	37.5	42.0
0.75	61.3	57.5	56.3	63.0
1	81.7	76.7	40.7	84.0
1.25	102.1	95.9	50.9	105.0
1.5	122.6	115.1	112.6	126.0
2	163.5	153.5	150.2	168.1
2.5	204.4	191.9	187.8	210.1
3	245.3	230.3	225.3	252.1

9.2

LVF-8008C-P0413

9.2.1

Flame detection

Opening angle 100°

Fire width (m)	A	B	C	D
0.3	15.6	10.6	8.3	18.4
0.5	26.0	17.7	13.8	30.7
0.75	39.1	26.6	20.8	46.1
1	52.2	35.5	27.7	61.5
1.25	65.3	44.4	34.7	76.9
1.5	78.4	53.3	41.6	92.3
2	104.6	71.1	55.5	123.1
2.5	130.8	88.9	69.4	153.9
3	156.9	106.7	83.3	184.7

Opening angle 90°

Fire width (m)	A	B	C	D
0.3	17.3	12.9	10.6	19.8
0.5	28.9	21.7	17.7	33.1
0.75	43.4	32.5	26.6	49.6
1	57.9	43.4	35.5	66.2
1.25	72.3	54.2	44.3	82.7
1.5	86.9	65.1	53.3	99.3
2	115.9	86.8	71.0	132.4
2.5	144.8	108.5	88.8	165.5
3	173.8	130.2	106.6	198.6

Opening angle 60°

Fire width (m)	A	B	C	D
0.3	26.3	23.4	21.8	27.6
0.5	43.9	39.1	36.4	46.0
0.75	65.9	58.7	54.7	69.1
1	87.9	78.2	73.0	92.1
1.25	109.9	97.9	91.3	115.2
1.5	131.9	117.4	109.5	138.2
2	175.9	156.6	146.1	184.3
2.5	219.9	195.8	182.6	230.4
3	263.9	235.0	219.2	276.5

Opening angle 45°

Fire width (m)	A	B	C	D
0.3	35.0	32.5	31.6	36.2
0.5	58.3	54.1	52.7	60.3
0.75	87.6	81.3	79.2	90.5
1	116.8	108.4	105.6	120.7
1.25	146.1	135.6	132.0	150.9
1.5	175.3	162.7	158.5	181.1
2	233.7	216.9	211.3	241.4
2.5	292.2	271.2	264.1	301.8
3	350.7	325.4	317.0	362.2

Opening angle 33°

Fire width (m)	A	B	C	D
0.3	47.4	46.1	45.4	48.4
0.5	79.0	77.0	75.7	80.7
0.75	118.5	115.4	113.5	121.0
1	158.1	154.0	151.4	161.4
1.25	197.5	192.5	189.2	201.7
1.5	237.1	231.0	227.1	242.1
2	316.2	308.1	302.8	322.8
2.5	395.2	385.1	378.5	403.5
3	474.3	462.1	454.2	484.2

9.2.2

Smoke detection

Opening angle 100°

Fire width (m)	A	B	C	D
0.3	10.9	7.4	5.8	12.9
0.5	18.2	12.4	9.7	21.5
0.75	27.4	18.6	14.5	32.3
1	36.6	24.9	19.4	43.1
1.25	45.7	31.0	24.2	53.8
1.5	54.9	37.3	29.1	64.6
2	73.2	49.8	38.9	86.2
2.5	91.5	62.2	48.6	107.7
3	109.9	74.7	58.3	129.3

Opening angle 90°

Fire width (m)	A	B	C	D
0.3	12.1	9.1	7.4	13.9
0.5	20.2	15.1	12.4	23.1
0.75	30.3	22.7	18.6	34.7
1	40.5	30.3	24.8	46.3
1.25	50.6	37.9	31.0	57.9
1.5	60.8	45.5	37.3	69.5
2	81.1	60.8	49.7	92.7
2.5	101.3	75.9	62.1	115.8
3	121.6	91.1	74.6	139.0

Opening angle 60°

Fire width (m)	A	B	C	D
0.3	18.4	16.4	15.3	19.3
0.5	30.7	27.3	25.5	32.2
0.75	46.1	41.0	38.2	48.3
1	61.5	54.8	51.1	64.5
1.25	76.9	68.5	63.9	80.6
1.5	92.2	82.1	76.6	96.7
2	123.1	109.6	102.2	129.0
2.5	153.9	137.1	127.8	161.3
3	184.6	164.4	153.4	193.5

Opening angle 45°

Fire width (m)	A	B	C	D
0.3	24.4	22.7	22.1	25.3
0.5	40.8	37.9	36.9	42.2
0.75	61.2	56.8	55.4	63.3
1	81.8	75.9	73.9	84.5
1.25	102.2	94.8	92.4	105.6
1.5	122.6	113.8	110.9	126.7
2	163.6	151.8	147.9	169.0
2.5	204.6	189.8	184.9	211.3
3	245.4	227.8	221.9	253.5

Opening angle 33°

Fire width (m)	A	B	C	D
0.3	33.1	32.2	31.7	33.8
0.5	55.2	53.8	52.9	56.4
0.75	82.9	80.8	79.4	84.7
1	110.6	107.7	46.2	112.9
1.25	138.3	134.7	57.8	141.2
1.5	165.9	161.6	158.9	169.4
2	221.3	215.6	211.9	225.9
2.5	276.6	269.5	264.9	282.4
3	332.0	323.4	317.9	338.9

Bosch Sicherheitssysteme GmbH

Robert-Bosch-Ring 5

85630 Grasbrunn

Germany

www.boschsecurity.com

© Bosch Sicherheitssysteme GmbH, 2023

Building solutions for a better life.

202301201449