



BOSCH

Pendant transmitter, 433MHz

SEC-RFPB60M-433



en

Installation Manual

Table of contents

1	Copyright, safety and warranty	4
1.1	Copyright information	4
1.2	Important safety notes	5
1.3	Safety precautions	6
1.4	Certification information	6
1.4.1	FCC/IC information	6
1.4.2	Other certification information	7
2	System overview	8
3	Installing the transmitter	9
4	Using the transmitter	13
4.1	Supervision feature of the transmitter	13
4.2	Generating a manual duress alarm	13
4.3	Resetting transmitter alarm	13
4.4	Testing the transmitter	14

1 Copyright, safety and warranty

1.1 Copyright information

All rights reserved. No part of this manual may be reproduced, stored in a retrieval system, or transmitted in any form or by any means, electronic, mechanical, photocopying, recording, or otherwise, without the prior written permission of BOSCH SECURITY SYSTEMS.

This manual is provided pursuant to a license agreement containing restrictions on their use. The manual contains valuable trade secrets and proprietary information of BOSCH SECURITY SYSTEMS and is protected by international copyright law. It may not be copied or distributed to third parties, or used in any manner not provided for in the said license agreement.

All software is provided "AS IS." The sole obligation of BOSCH SECURITY SYSTEMS shall be to make available all published modifications that correct program problems are published within one (1) year from the date of shipment.

The software is intended for use only with the hardware specified in this manual and in the absence of other software. Concurrent use with other software or with hardware not specified may cause the program to function improperly or not at all. BOSCH SECURITY SYSTEMS may not provide support for systems operating under such conditions.

All efforts have been made to ensure the accuracy of the contents of this manual. The above notwithstanding, BOSCH SECURITY SYSTEMS assume no responsibility for any errors in this manual or their consequences.

The information on this document is subject to change without notice.

Other product and company names mentioned herein may be the trademarks of their respective owners.

1.2 Important safety notes

1. **Read, Follow, and Retain Instructions** – All safety and operating instructions must be read and followed properly before putting the unit into operation. Retain instructions for future reference.
2. **Consider all Warnings** – Adhere to all warnings on the unit and in the operating instructions.
3. **Accessories** – Use only accessories recommended by the manufacturer or those sold with the product. Accessories not recommended by the manufacturer shall not be used, as they may cause hazards.
4. **Installation Precautions** – Do not place this unit on an unstable stand, tripod, bracket, or mount. The unit may fall, causing serious injury to persons and damage to the unit. Mount the unit according to the manufacturer's instructions.
5. **Service** – Do not attempt to service this unit by yourself. Opening or removing covers may expose you to dangerous voltages or other hazards. Refer all servicing to qualified service personnel.
6. **Damage Requiring Service** – Disconnect the unit from the main AC or DC power source and refer servicing to qualified service personnel under the following conditions:
 - When the power supply cord or plug is damaged.
 - If liquid has been spilled or an object has fallen into the unit.
 - If the unit has been exposed to water and/or inclement weather (rain, snow, etc.).
 - If the unit does not operate normally, when following the operating instructions. Adjust only those controls specified in the operating instructions. Improper adjustment of other controls may result in damage, and require extensive work by a qualified technician to restore the unit to normal operation.
 - If the unit has been dropped or the cabinet damaged.
 - If the unit exhibits a distinct change in performance, this indicates that service is needed.
7. **Replacement Parts** – When replacement parts are required, the service technician shall use replacement parts that are specified by the manufacturer. Unauthorized substitutions may result in fire, electrical shock or other hazards.
8. **Safety Check** – Upon completion of service or repair work on the unit, ask the service technician to perform safety checks to ensure that the unit operates properly.
9. **Power Sources** – Operate the unit only from the type of power source indicated on the label. If unsure of the type of power supply to use, contact your dealer.
 - For units intended to operate from battery power, refer to the operating instructions.
 - For units intended to operate with External Power Supplies, use only the recommended approved power supplies.
10. **Lightning** – For added protection during a lightning storm, or when this unit is left unused for long periods of time, disconnect the unit from power. This will prevent damage to the unit due to lightning and excessive power line surges.
11. **Restricted Access Locations** are required for the installation.

1.3 Safety precautions

	<p>Disposal</p> <p>Your Bosch product has been developed and manufactured using high-quality materials and components that can be reused.</p> <p>This symbol means that electronic and electrical devices that have reached the end of their working life must be disposed of separately from household waste.</p> <p>In the EU, separate collecting systems are already in place for used electrical and electronic products. Please dispose of these devices at your local communal waste collection point or at a recycling center.</p>
-----------------------------------------------------------------------------------	---------------------------------------------------------------------------------------------------------------------------------------------------------------------------------------------------------------------------------------------------------------------------------------------------------------------------------------------------------------------------------------------------------------------------------------------------------------------------------------------------------------------------------------------------

1.4 Certification information

1.4.1 FCC/IC information

This device complies with Part 15 FCC Rules and Industry Canada's license-exempt RSSs. Operation is subject to the following two conditions: (1) this device may not cause harmful interference, and (2) this device must accept any interference received including interference that may cause undesired operation.

Le présent appareil est conforme aux CNR d'Industrie Canada applicables aux appareils radio exempts de licence. L'exploitation est autorisée aux deux conditions suivantes: (1) l'appareil ne doit pas produire de brouillage, et (2) l'utilisateur de l'appareil doit accepter tout brouillage radioélectrique subi, même si le brouillage est susceptible d'en compromettre le fonctionnement.

Changes or modifications not expressly approved by the party responsible for compliance could void the user's authority to operate the equipment.

This equipment has been tested and found to comply with the limits for a Class B digital device, pursuant to Part 15 of the FCC Rules. These limits are designed to provide reasonable protection against harmful interference in a residential installation. This equipment generates, uses and can radiate radio frequency energy and, if not installed and used in accordance with the instructions, may cause harmful interference to radio communications. However, there is no guarantee that interference will not occur in a particular installation.

If this equipment does cause harmful interference to radio or television reception, which can be determined by turning the equipment off and on, the user is encouraged to try to correct the interference by one or more of the following measures:

1. Reorient or relocate the receiving antenna.
2. Increase the separation between the equipment and receiver.
3. Connect the equipment into an outlet on a circuit different from that to which the receiver is connected.
4. Consult the dealer or an experienced radio/TV technician for help.

1.4.2

Other certification information

Complies with
IMDA Standards
DA105282

2 System overview

The Security Escort pendant transmitters are security transmitters designed to work with the Security Escort system. In normal supervision mode, the transmitter sends a signal to the central console at regular fixed intervals, to notify the system of its last known location. During an emergency, the subscriber initiates an alarm. The alarm signal identifying the transmitter and its location is sent to the Security Escort central console. During the alarm, the auto-tracking feature sends a signal to the central console at short successive intervals to constantly update and track its location.

3 Installing the transmitter

This section provides information on how to install the battery and set up the transmitter. The transmitter uses a 3 VDC, CR2032 lithium coin cell battery. The following battery types are recommended: Duracell® DL2032, Eveready® CR2032, or Panasonic® CR2032. Assuming normal usage (such as weekly testing), the battery life of SEC-RFPB60M-433 should be approximately 3 years.

**Notice!**

This equipment can be damaged by static electricity. Use a ground strap or grounded workstation when changing batteries.

You need a Phillips P1 screwdriver to install or replace the batteries.

1. Use the screwdriver to remove the screw from the back cover of the transmitter.

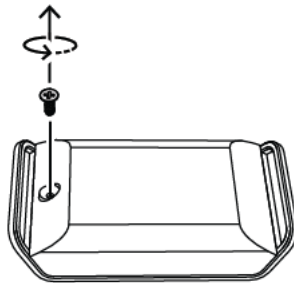

2. Remove the back cover from the transmitter.

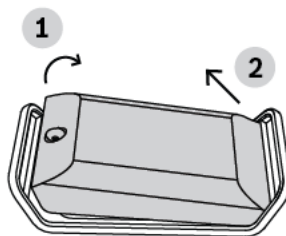

3. Insert or replace the battery, placing the positive (+) polarity facing the inside of the transmitter.

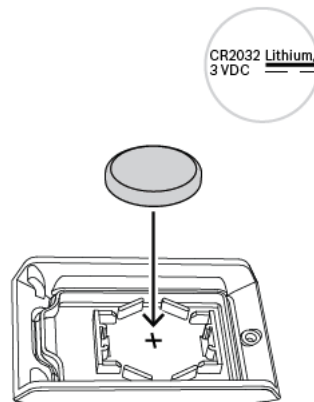
**Caution!**

Risk of explosion

Replacement of the battery with an incorrect type is subject to the risk of explosion. Batteries must not be disposed of in household waste to avoid the risk of explosion.

4. Place the back cover of the transmitter into its original position.

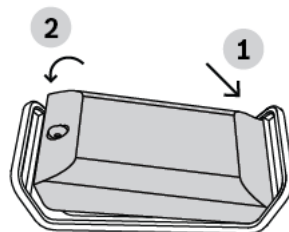

5. Insert and fasten the screw of the back cover.

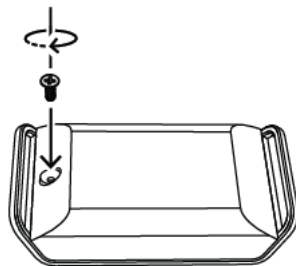

6. Register the transmitter in the Security Escort database using the RFID code at the back of the transmitter, if necessary.



7. Test the transmitter for proper operation by generating an alarm.

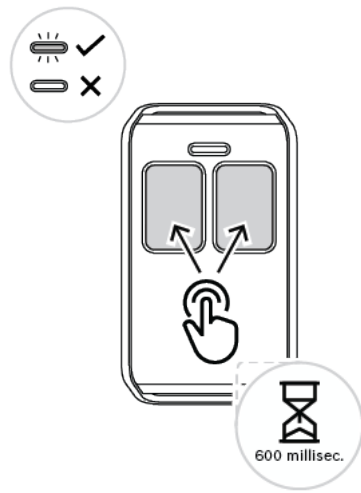

4 Using the transmitter

This section provides information on the features and how to use the transmitter.

4.1 Supervision feature of the transmitter

Supervision is provided by transmitting a low power level signal to the receiver every 60 minutes if there is no other activity. The supervision duration is fixed and non-configurable.

4.2 Generating a manual duress alarm

During an emergency, the subscriber presses and holds both alarm buttons simultaneously for 600 milliseconds or more to generate a duress alarm. The LED starts blinking and illuminate for a longer period one final time. This is when the transmitter sends an alarm signal to the central console, and the LED of the transmitter then turns off.

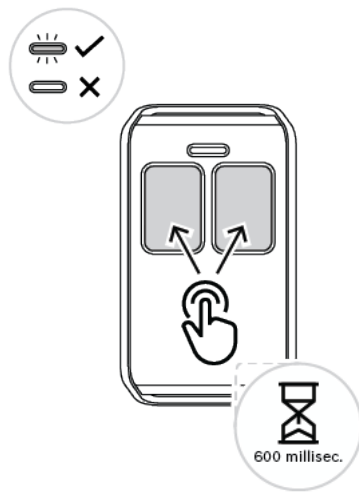

Figure 4.1: Generating a manual duress alarm

The same result can be achieved by pressing and holding one of the alarm buttons. Without releasing this alarm button, press and hold the other unused alarm button for 600 milliseconds or more to generate a duress alarm.

After the alarm is initiated, the auto-tracking feature begins. The transmitter continues to transmit its location to the central console automatically every 10 seconds, for a duration of 10 minutes.

4.3 Resetting transmitter alarm

To reset the transmitter during the auto-tracking period after generating a manual duress alarm, perform a test sequence as described in *Testing the transmitter, page 14*. Otherwise, the transmitter will time out after 10 minutes and automatically reset to the normal state.

4.4 Testing the transmitter

To start the test sequence, press either one of the buttons on the transmitter for about 1 second. The LED of the transmitter will start to blink rapidly.

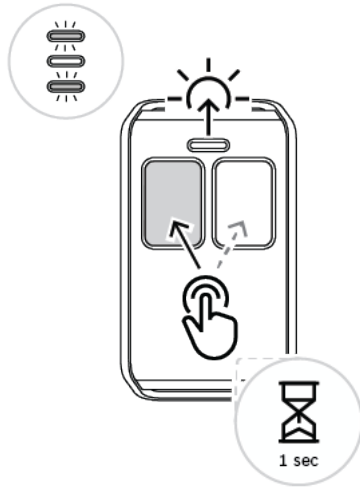

Figure 4.2: Press either one of the buttons to start the test sequence

To complete the test sequence before the transmitter times out after 3 seconds, press the other unutilized button for about 1 second. The LED of the transmitter continues to blink rapidly during this period.

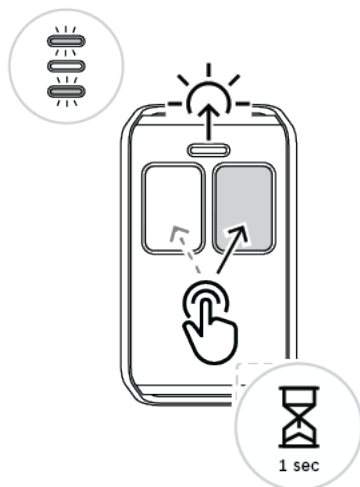
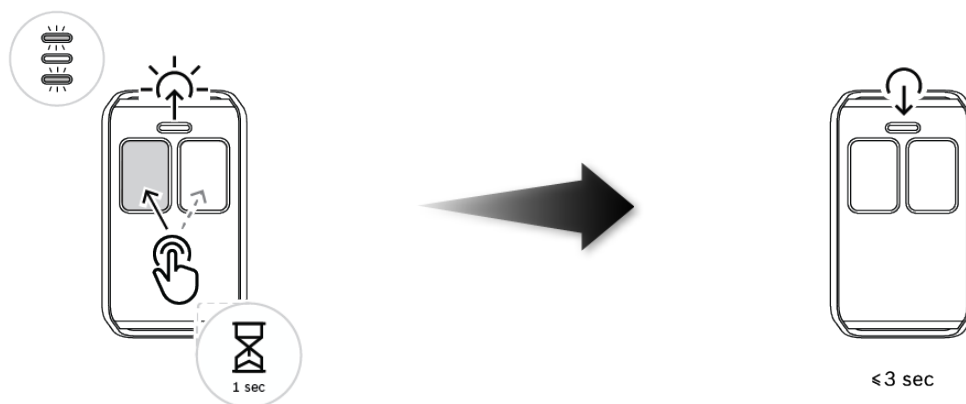

Figure 4.3: Press the other unutilized button before the 3 seconds time out

If the test sequence is completed successfully, the LED of the transmitter will illuminate for a longer period a final time. A test transmission is sent to the central console and the LED of the transmitter will switch off.

You may abort the test by not doing anything after starting the test sequence, and letting it time out after 3 seconds. The LED of the transmitter will stop blinking after the test sequence has timed out.





Bosch Security Systems B.V.

Torenallee 49

5617 BA Eindhoven

Netherlands

www.boschsecurity.com

© Bosch Security Systems B.V., 2019